



Process Center AB

Vibrerande nivåvakter Serie SC

www.processcenter.se



Process Center AB
Skogsbrynsvägen 8 C
236 31 Höllviken
040 452900 info@processcenter.se



Vibrerande nivåvakter Serie SC

www.processcenter.se

PRODUCT INTRODUCTION

WORKING PRINCIPLE

The Finetek vibrating probe switch is highly versatile and can be used for most almost any bulk solid application. This includes level detection of almost any granular, sandy, chip like, foodstuff, grain or powdery materials.

The operating principle is based on the changes of vibration frequency of the tuning fork when it comes into contact with a liquid or solid material..

The Vibrating probe contains piezoelectric crystals built into the vibration tube that produce vibrations/resonations at specific frequencies. One element acts as a transmitter of the signal and the other receives the signal and converts it to electrical output.

When the Vibrating probe comes in contact with material the vibration is weakened/dampened and results in a frequency change which triggers the switch. It's ideal for applications where: the dielectric constant is low (where capacitance level switches can't be used) ; when material moisture content changes easily; low viscosity liquids; there is a combination of differing materials in the container/tank.

The Vibrating probe provides a reliable & maintenance-free means of process control for bulk solids. Easy mounting at almost any angle and basic calibration procedures will provide reliable functioning and less required monitoring. This device can withstand tough lateral loads and static electricity.

Furthermore, it eliminates the application issues associated with jamming and clogging between tines on a 'tuning fork' device Also; it is equipped with a Fail-safe that prevents malfunctioning caused by power cuts

FEATURES

- Voltage supply range 20~250, 50~60Hz Vac/ Vdc.
- SPDT Relay output, SSR MOSFET output.
- Sensitivity adjustment is available for different density mediums.
- Low wear and tear, maintenance free and self cleaning.
- Fine powders can be detected.
- Euro and UL certified Models available.

APPLICATION

Solid Level Detection
Powders:

Powdered milk, flour, spices, coffee beans, coffee powder, tea, salt, sugar, grains, chocolate
Tobacco, powdered cellulose, powdered clay, polystyrene powder, dry soot, soda ash, coal ash

Granular & plastics:

Gravel, glass fine power, granular plastics, foundry sand, cements, plastic pellets

Chip or pellet like:

Frozen potato chips, beans, peanuts, sweets and candy, animal / pet food
Wood shavings, chalk, steering chips, styrofoams, charcoals

BENEFITS

- No calibration required, easy use, sturdy and durable
- Rounded design prevents medium build up on probe
- Operates well under high temperature, humid and moist conditions
- High vibration force
(also helps shake off build up)
- Fine powers can be detected.

Structure & Dimension

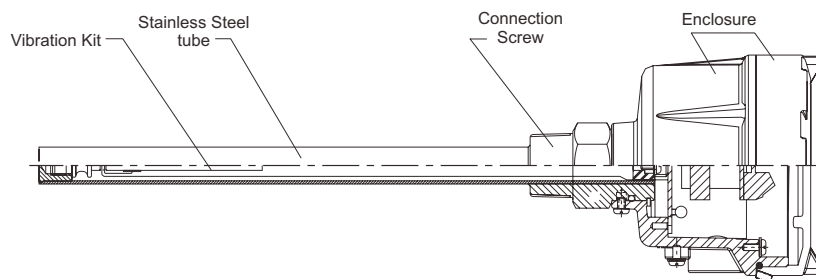



Vibrerande nivåvakter Serie SC

www.processcenter.se

SPECIFICATIONS

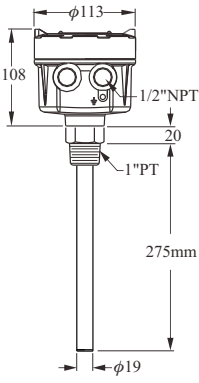
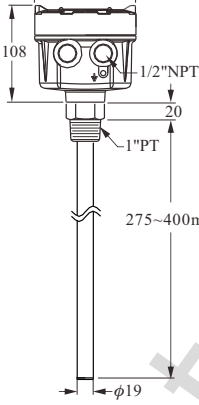
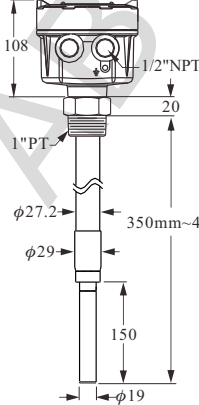
Dimensions (Unit:mm)			
Order No.	SC2100 【Standard Model】	SC2110 【Probe Extension Model】	SC2120 【Ultra Extension Model】
Level sensor housing	Aluminum / IP65		
Probe construction	SUS 304 / 316		
Mounting	1"PT		
Conduit	1/2"NPT × 2		
Max. vertical load on rod.	177in.Lbs(20Nm)		
Operating pressure.	-1~150PSI (10BAR)		
Power supply	20~250, 50/60Hz Vac/ Vdc		
Power consumption	15VA (Max.)		
Operating temp. in ambient air	-40°C~60°C		
Operating temp. in bin	-40°C~80°C		
Signal output	Relay, SPDT, 5A/250Vac, PNP/NPN(MOSFET)400mA/60 Vac/ Vdc		
Min. material density sensed	Solid: ≥0.32g/cm ³		
Time delay	0.6~1 Second / Operate; 2~5 Seconds / Reset		
Remote-test	Yes		
Vibrating frequency.	395~405HZ		
Selectable Fail-safe	Hi./ Lo.		
Selectable sensitivity	Hi./ Lo.		



Vibrerande nivåvakter Serie SC

www.processcenter.se

SPECIFICATIONS

<p>Dimensions (Unit:mm)</p>			
<p>Order No.</p>	<p>SC2300 【Cable Extension Model】</p>	<p>SC2500 【Corrosion-Proof】</p>	<p>SC2510 【Corrosion-Proof & Extension Typ】</p>
<p>Level sensor housing</p>	<p>Aluminum / IP65</p>		
<p>Probe construction</p>	<p>SUS 304 / 316</p>	<p>SUS 304/316 Coating TEFLON</p>	<p>SUS 304/316 Coating TEFLON</p>
<p>Mounting</p>	<p>1"PT</p>	<p>Flange 1"(min.)</p>	<p>Flange 1"(min.)</p>
<p>Conduit</p>	<p>1/2"NPT × 2</p>		
<p>Max. vertical load on rod.</p>	<p>177in.Lbs(20Nm)</p>		
<p>Operating pressure.</p>	<p>-1~150PSI (10BAR)</p>	<p>-1~150PSI (10BAR)</p>	<p>-1~150PSI (10BAR)</p>
<p>Power supply</p>	<p>20~250, 50/60Hz Vac/ Vdc</p>		
<p>Power consumption</p>	<p>15VA (Max.)</p>		
<p>Operating temp. in ambient air</p>	<p>-40°C~60°C</p>		
<p>Operating temp. in bin</p>	<p>-40°C~80°C</p>		
<p>Signal output</p>	<p>Relay, SPDT, 5A/250Vac, PNP/NPN(MOSFET)400mA/60 Vac/ Vdc</p>		
<p>Min. material density sensed</p>	<p>Solid: ≥0.32g/cm³</p>		
<p>Time delay</p>	<p>0.6~1 Second / Operate; 2~5 Seconds / Reset</p>		
<p>Remote-test</p>	<p>Yes</p>		
<p>Vibrating frequency.</p>	<p>395~405HZ</p>		
<p>Selectable Fail-safe</p>	<p>Hi./ Lo.</p>		
<p>Selectable sensitivity</p>	<p>Hi./ Lo.</p>		



Vibrerande nivåvakter Serie SC

www.processcenter.se

PTB PROOF NO. 05 ATEX 1026 Ex II 2G Ex d IIB T6 Gb

Ex II 2D Ex tb IIIC T85°C Db IP65

SPECIFICATIONS

Dimensions (Unit:mm)			
Order No.	SC1700 【Standard Type】	SC1701 【Probe Extension Type】	SC1710 【Ultra Extension Type】
Level sensor housing	Aluminium		
Probe construction	SUS 304 / 316		
Mounting	Screw: 1"PT or PF, Flange: 1"~6"JIS / DIN / ANSI		
Conduit	1/2"NPT×2		
Max. vertical load on rod.	177in.Lbs(20Nm)		
Operating pressure.	-1~150PSI (10BAR)		
Power supply	20~250Vac/dc		
Power consumption	15W		
Operating temp. in ambient air	-20°C~70°C		
Operating temp. in bin	-40°C~80°C		
Signal output	Relay, SPDT , 3A/250Vac Max.		
Min. material density sensed	Solid: ≥0.32g/cm ³		
Time delay	0.6 Second / Operate; 2~5 Seconds / Reset		
Vibrating frequency.	395~405HZ		
Selectable Fail-safe	Hi./ Lo.		
Selectable sensitivity	Hi./ Lo.		



Vibrerande nivåvakter Serie SC

INSTALLATION

Vertical Installation (Figure 1):

1. Install the vibrating probe away from the inlet to avoid material impact or false readings.
2. Note the material flow pattern and place the vibrating probe in the appropriate position to avoid overflow.

Horizontal Installation (Figure 2)

1. Install the vibrating probe away from the inlet to avoid material impact. If this is unavoidable make use of a shield or barrier for protection.
2. Installing the vibrating probe at a 20 degree incline will optimize the results and increase sensitivity.
3. Keep the conduit facing downward to avoid moisture getting inside the housing.

Notice:

1. Users are advised to tighten the connection by using a spanner.
2. Do not bend the probe, put force on it or attempt to modify the probe length.
3. The maximum vertical pressure of the vibrating probe is 177in.Lbs (20Nm)

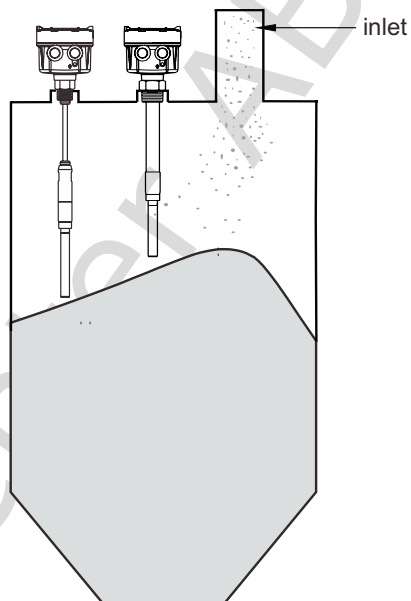

Figure 1

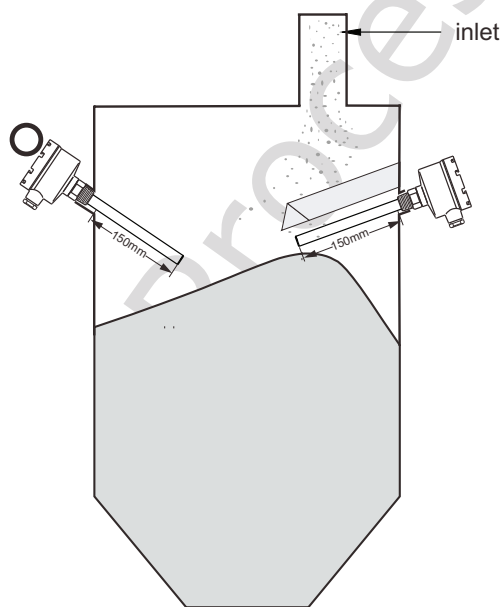

Figure 2

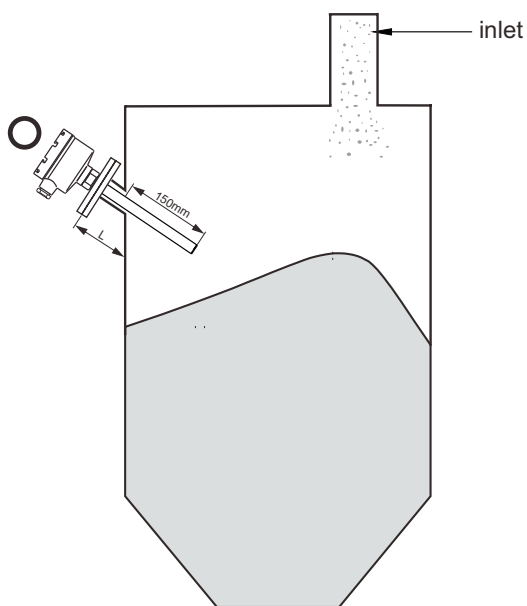

Figure 3



Vibrerande nivåvakter Serie SC

OPERATING INSTRUCTIONS (EURO MODEL)

SC2100X, SC2110X, SC2200X, SC2210X, SC2300X, SC2500X, SC1700X, SC1701X, SC1710X

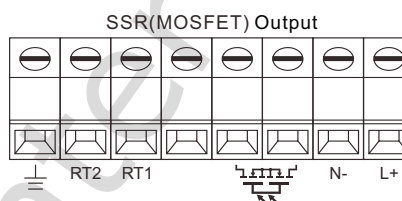
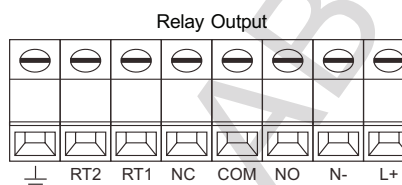
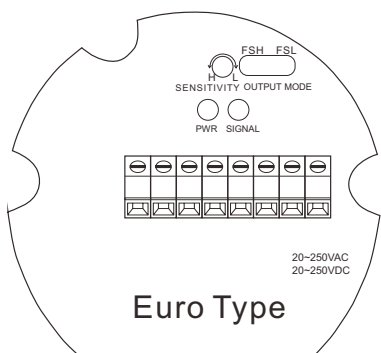

Terminal Function

- L+, N-: Power Supply
- NC, COM, No: Relay Output
- RT1, RT2: Remote-Test
- \perp : Ground Connection
- : SSR(MOSFET) Output

Panel Function

- PWR: Power Supply (Green Light)
- SIGNAL: Output Indication (Red Light)
- FSH: Power On. The signal lamp is on and the relay is conductive. While the vibrating probe senses the material, the signal lamp is off and relay is not conductive.
- FSL: Power On. The signal lamp is off and the relay is not conductive. While the probe senses the material, the signal lamp is on and relay is conductive.
- SENSITIVITY L: Low Sensitivity
- SENSITIVITY H: High Sensitivity

Sensitivity Adjustment

1. SENSITIVITY: Located upside of PCB. When switching to H position, it has the highest sensitivity. When switching to L position, it has the lowest sensitivity. The original setting is at L position and users are able to adjust the sensitivity depends on the specific gravity of material.

- H: High Sensitivity (Suitable for detecting low specific gravity material)
- L : Low Sensitivity (Suitable for detecting low specific gravity material)

Fail-Safe High / Low Protection

FSH (Fail-Safe High) Protection:

Switch to FSH mode.

Normal Status: The signal lamp is on. It means that the vibrating probe does not sense the material and the relay is conductive.

Failure: When the power shuts down, the signal lamp is off. It means that the vibrating probe is voided and the relay is not conductive.

FSL (Fail-Safe Low) Protection:

Switch to FSL mode.

Normal Status: The signal lamp is on. The vibrating probe senses the material and the relay is conductive.

Failure: When the power shuts down, the signal lamp is off. The vibrating probe is voided and the relay is not conductive.

	FSL		FSH	
Level				
Contact Form	NO COM NC	NO COM NC	NO COM NC	NO COM NC
Indication				
Status	Fail	Normal	Normal	Fail



Vibrerande nivåvakter Serie SC

www.processcenter.se

OPERATING INSTRUCTIONS (UL MODEL)

SC2100X, SC2110X, SC2200X, SC2210X, SC2300X, SC2500X, SC1700X, SC1701X, SC1710X

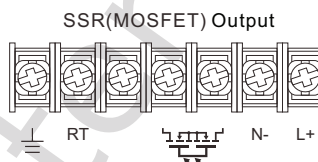
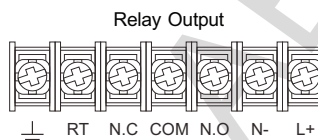
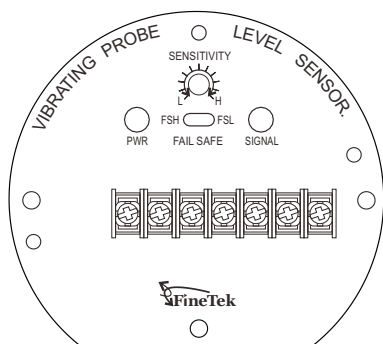

Terminal Function

- L+, N-: Power Supply
- NC, COM, No: Relay Output
- RT: Remote-Test
- \perp : Ground Connection
- : SSR(MOSFET) Output

Panel Function

- PWR: Power Supply (Green Light)
- SIGNAL: Output Indication (Red Light)
- FSH: Power On. The signal lamp is on and the relay is conductive. While the vibrating probe senses the material, the signal lamp is off and relay is not conductive.
- FSL: Power On. The signal lamp is off and the relay is not conductive. While the probe senses the material, the signal lamp is on and relay is conductive.
- SENSITIVITY L: Low Sensitivity
- SENSITIVITY H: High Sensitivity

Sensitivity Adjustment

1. SENSITIVITY: Located upside of PCB. When switching to H position, it has the highest sensitivity. When switching to L position, it has the lowest sensitivity. The original setting is at L position and users are able to adjust the sensitivity depends on the specific gravity of material.

- H: High Sensitivity (Suitable for detecting low specific gravity material)
- L: Low Sensitivity (Suitable for detecting low specific gravity material)

Fail-Safe High / Low Protection

FSH (Fail-Safe High) Protection:

Switch to FSH mode.

Normal Status: The signal lamp is on. It means that the vibrating probe does not sense the material and the relay is conductive.

Failure: When the power shuts down, the signal lamp is off. It means that the vibrating probe is voided and the relay is not conductive.

FSL (Fail-Safe Low) Protection:

Switch to FSL mode.

Normal Status: The signal lamp is on. The vibrating probe senses the material and the relay is conductive.

Failure: When the power shuts down, the signal lamp is off. The vibrating probe is voided and the relay is not conductive.

	FSL		FSH	
Level				
Contact Form				
Indication				
Status	Fail	Normal	Normal	Fail



Vibrerande nivåvakter Serie SC

www.processcenter.se

HOW TO ORDER

SC () ()

ORDER NO.

- 2100: Standard Model
- 2110: Extension Model
- 2120: Vibrating Probe Ultra Extension Model
- 2300: Cable Extension Model
- 2500: Corrosion Proof Model
- Explosion Proof models
- 1700: Standard
- 1701: Extension
- 1710: Ultra Extension

POWER & OUTPUT MODULE

- 20~250Vac/ Vdc, 50/60Hz
- A: Relay O/P (Barrier terminal block-limited to the 17's and 21's series)
- B: Transistor PNP/NPN (Barrier terminal block-limited to the 17's and 21's series)
- R: Relay O/P (Green terminal)-EuroType
- N: Transistor PNP/NPN-EuroType

MATERIAL

- 0: SUS304 6: SUS316 P: PTFE

CONNECTION

Dimension	Specification
D---1"(25A)	M---5kg/cm ² Y---PN 25
3---1-1/4"(32A)	N---10kg/cm ² Z---PN 40
E---1-1/2"(40A)	O---150 Lbs S---others
F---2"(50A)	P---300 Lbs 9---Sanitary
G---2-1/2"(65A)	Q---PT
H---3"(80A)	R---PF(G)
I---4"(100A)	T---BSP
J---5"(125A)	U---NPT
K---6"(150A)	W---PN 10
S---others	X---PN 16

LENGTH (L) (UNIT: cm)

- 0500: below 500mm
 - 1000: 501~1000mm
 - 1500: 1001~1500mm
 - ⋮
- ※ 500mm per Unit
 ※ The letter A depicts lengths longer than 10m: A150 =15m, A200 = 20m

CHECK – before placing order

1. Check the voltage.
2. Check the mounting positions.
3. Check the material specific gravity (S.G.) value.
4. Check whether any bridge block or vibrating motors are attached to the silo wall.

Length tolerance/margin of error : 65mm
 Characteristics, specifications and dimensions are subject to change
 Please contact your nearest distributor for further information.