



Process Center AB

Nivåindikator EF Bypass

www.processcenter.se



By-Pass Level Transmitter



www.fine-tek.com

Process Center AB
Skogsbrynsvägen 8 C
236 31 Höllviken
040 452900 info@processcenter.se



INTRODUCTION

INTRODUCTION

The By-Pass Level Indicator is installed outside of a vessel or tank. The liquid level in the tank can easily be observed from the change of the flag color. Optional devices of magnetic switch and level transducer can be added for electrical signal output and level transmitting.

PRINCIPLE

Fine-Tek's By-Pass indicator utilizes hydrostatic principle to show the liquid level in the tank. A float with a magnet inside rises and drops according to the liquid level change. Magnetic flags will flip as float passes through to indicate liquid level based on magnetic attraction method.

APPLICATIONS AND FEATURES

- Applicable in environment with high temp., high pressure, strong acid, strong alkaline and hazardous locations. The structure is simple but durable and reliable. It is also available with various options for upgrade.
- A level transducer or magnetic switch can be installed and adjusted during operation.
- It is not operated by electricity thus it will not be affected by power failure.
- Add different color of flag per 10cm that can be recognized easily.
- Multiple applications for textile dyeing, sewage water processing, power generating, boiler and petrochemical industries.

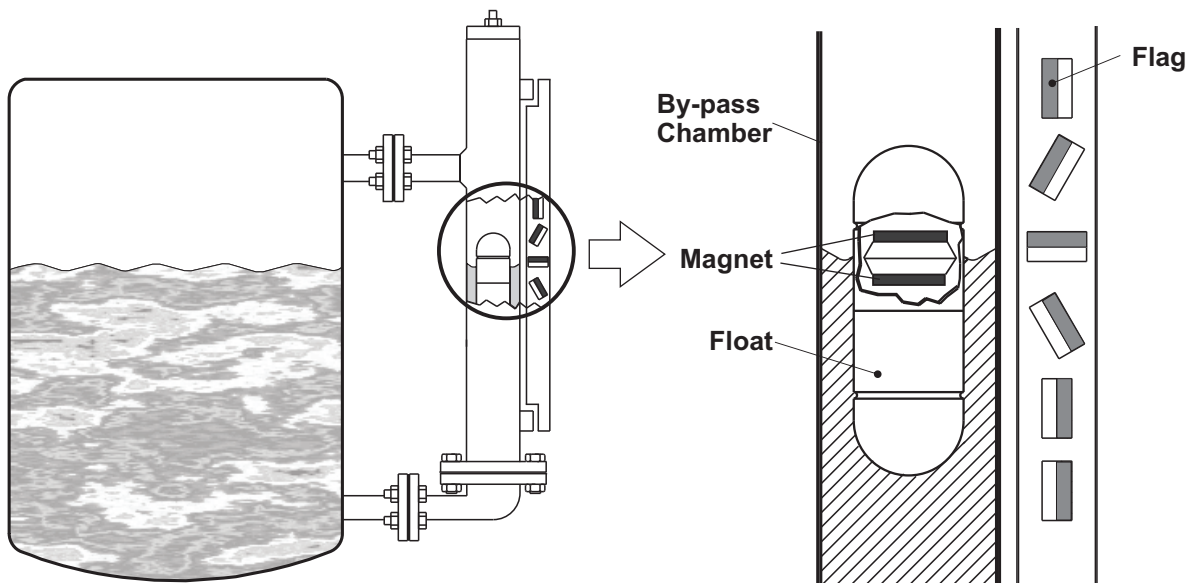



PRODUCT WITH PATENT RECOMMENDATION

1.) Magnetic Switch (Fig.1)

- * The plastic miniature magnetic switch is anti-corrosive and with IP67 rating. It is the smallest magnetic switch in the current market.
- * The magnetic switch is easy to set up and has real time adjustment.

2.) Innovative Design For Bottom End Flange and the Connecting Flange (Fig.2)

- * The lower center duct is at the bottom end of the chamber. When the liquid drains in the tank, there will be no residue in the chamber unit.
- * This is suitable for production that requires frequent liquid change and mixture is not allowed during the process.

3.) Removable Duct and Connecting Flange (Fig.3)

- * The flange setting is close to the two ends of the chamber, therefore the "C-C" distance is maximized.
- * It is strengthened in the structure by a large phase weld.
- * During the installation, adjust the flange to the fitting mounting holes.

TYPE: EF-□-B1L

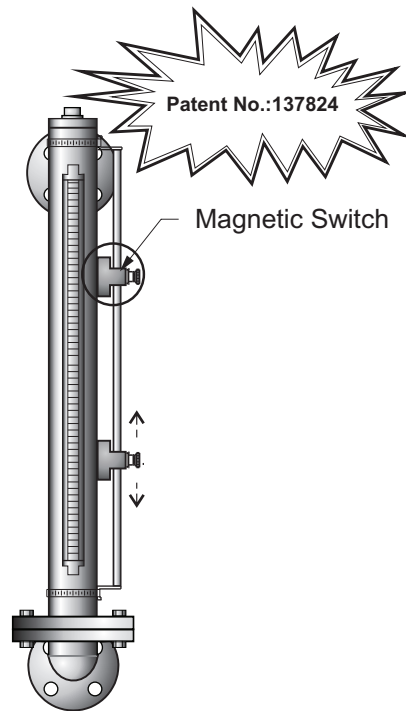
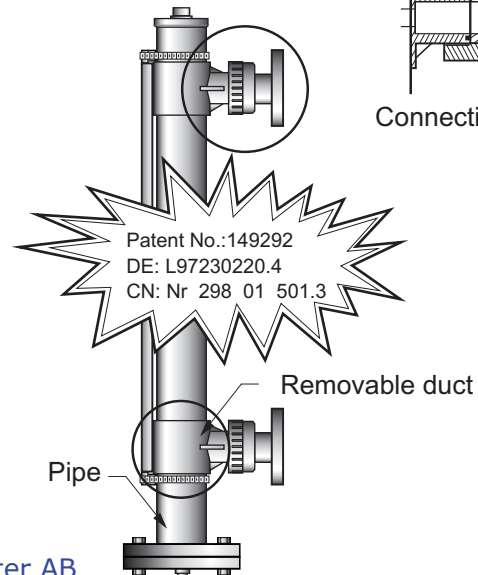
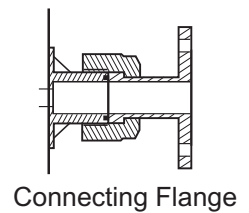
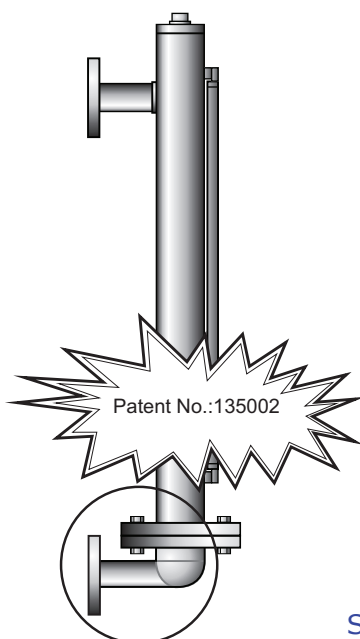

Fig.1

TYPE: EF - □ - B1L





Process Center AB

Nivåindikator EF Bypass

www.processcenter.se

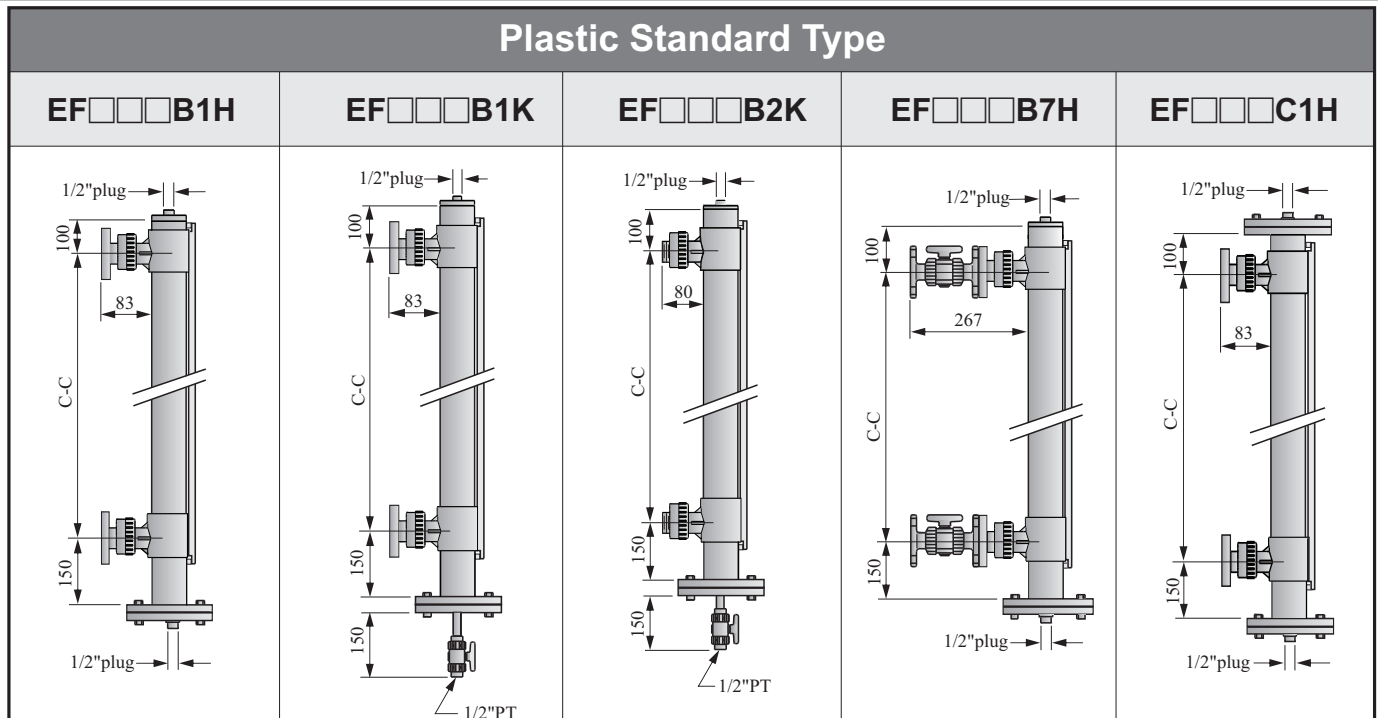

SPECIFICATIONS:

Model No. Description	EF□□□B1H	EF□□□B1K	EF□□□B2K	EF□□□B7H	EF□□□C1H
Top End	Flat top with 1/2"PT plug				Dual flange with 1/2"PT plug
Bottom End	Dual flange with 1/2"PT plug	Dual flange with 1/2"PT drain valve		Dual flange with 1/2"PT plug	
Connecting	3/4" x10kg/cm ² (Flange)		3/4" or 1"PT (Screw)	3/4" x10kg/cm ² (Ball Valve)	3/4" x10kg/cm ² (Flange)
C-C Distance	Min. 150mm; Max. 3800mm				
Operation Pressure	5kg/cm ²				
Operation Temp.	PP: 80°C, PVDF: 120°C				
Chamber	PP: φ60.5 x 3.8t, PVDF: φ63 x 3.2t				
Float Type	EFB-2500 (PVDF) / 2510 (PP) (see page 9)				
Material	PP / PVDF				
Flag Indicator	EFB-0750 (140°C) (see page 10)				
Ruler	Option (see page 11)				

Process Center AB
Skogsbrynsvägen 8 C
236 31 Höllviken
040 452900 info@processcenter.se



Nivåindikator EF Bypass

www.processcenter.se

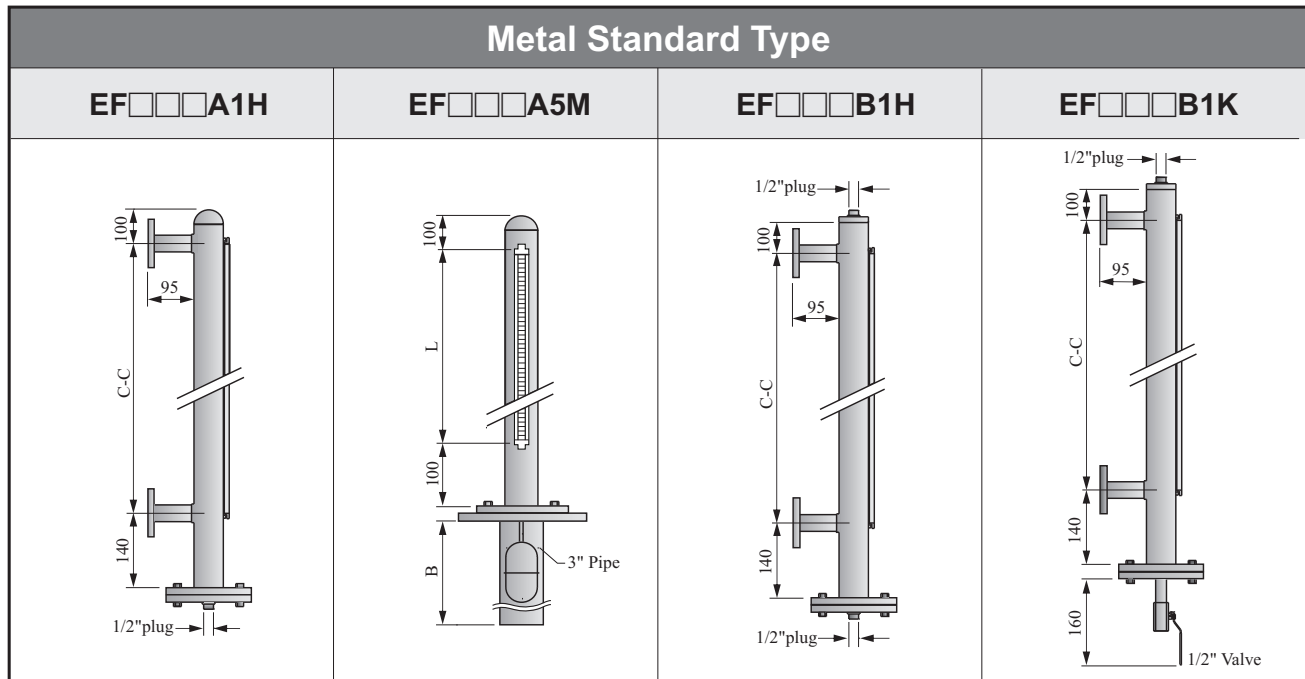

SPECIFICATIONS:

Model No. Description	EF□□□A1H	EF□□□A5M	EF□□□B1H	EF□□□B1K
Top End	Cap		Flat top with 1/2"PT plug	
Bottom End	Dual flange with 1/2"PT plug	Dual flange with 3" shield pipe	Dual flange with 1/2"PT plug	Dual flange with 1/2" drain valve
Bottom Flange	1-1/2" x 5kg/cm ²	3-1/2" x 5kg/cm ²	1-1/2" x 5kg/cm ²	
Connecting	3/4" x 10kg/cm ² (Flange)	3" (Hole)	3/4" x 10kg/cm ² (Flange)	
C-C Distance Flag Display Length(L)	Min. 150mm; Max. 5,800mm	Min. 150mm; Max. 2,000mm	Min. 150mm; Max. 5.800mm	
Operation Pressure	25kg/cm ² (Max. 50kg/cm ²)			20kg/cm ²
Operation Temp.	SUS304: 140°C, 200°C, 400°C SUS316: 140°C, 200°C, 400°C			SUS304: 140°C, 200°C, 350°C SUS316: 140°C, 200°C, 350°C
Chamber	φ60.5 x 2.8t			
Float Type	EFB-2580 (see page 9)			
Material	SUS304 / SUS316			
Flag Indicator	EFB-0700 (200°C), EFB-0740 (400°C), EFB-0750 (140°C) (see page 10)			
Ruler	Option (see page 11)			



Nivåindikator EF Bypass

www.processcenter.se

Metal Standard Type			
EF□□□B2K	EF□□□B7H	EF□□□C1H	EF□□□B1L

* The pipe is so long that support rack is needed to prevent pipe from bending.

SPECIFICATIONS:

Model No.	EF□□□B2K	EF□□□B7H	EF□□□C1H	EF□□□B1L
Description				
Top End	Flat top with 1/2"PT plug		Dual flange with 1/2"PT plug	Flat top with 1/2"PT plug
Bottom End	Dual flange with 1/2" drain valve	Dual flange with 1/2"PT plug		Dual flange+angle pipe
Bottom Flange	1-1/2" x 5kg/cm ²			—
Connecting	3/4"PT or 1"PT (Screw)	3/4" x 10kg/cm ² (Ball Valve)	3/4" x 10kg/cm ² (Flange)	
C-C Distance	Min. 150mm; Max. 5,800mm			
Operation Pressure	20kg/cm ²	10kg/cm ²	25kg/cm ² (Max. 50kg/cm ²)	
Operation Temp.	SUS304: 140°C, 200°C, 350°C SUS316: 140°C, 200°C, 350°C		SUS304: 140°C, 200°C, 400°C SUS316: 140°C, 200°C, 400°C	SUS304: 140°C, 200°C SUS316: 140°C, 200°C
Chamber	φ60.5 x 2.8t			
Float Type	EFB-2580 (see page 9)			
Material	SUS304 / SUS316			
Flag Indicator	EFB-0700 (200°C), EFB-0740 (400°C), EFB-0750 (140°C) (see page 10)			
Ruler	Option (see page 11)			



Nivåindikator EF Bypass

www.processcenter.se

Blanket Type	Jacket Type	Heating Type
EF□□□C1H	EF□□□C8H	EF□□□B1H

SPECIFICATIONS:

Model No. Description	EF□□□C1H	EF□A/B□C1H	EF□□□B1H
Top End	Dual flange with 1/2"PT plug		Dual flange with 1/2"PT plug
Bottom End	Dual flange with 1/2"PT plug		Dual flange with 1/2"PT plug
Connecting	3/4" x10kg/cm ² (Flange)	1-1/4" x 10kg/cm ²	3/4" x10kg/cm ² (Flange)
C-C Distance	Min. 150mm; Max. 5800mm		
Operation Pressure	25kg/cm ² (Max. 50kg/cm ²)		20kg/cm ²
Operation Temp.	SUS304: 140°C, 200°C, 400°C SUS316: 140°C, 200°C, 400°C		SUS304: 100°C SUS316: 100°C
Chamber	φ60.5 x 2.8t	Jacket φ76 x 3.0t 1/2"PT plug	φ 65 x 3.5t φ130 Heating type
Float Type	EFB-2580 (see page 9)		
Material	SUS304 / SUS316		
Flag Indicator	EFB-0700 (200°C), EFB-0740 (400°C), EFB-0750 (140°C) (see page 10)		
Ruler	Option (see page 11)		



Nivåindikator EF Bypass

www.processcenter.se

Antiseptic Type	High Pressure Type
EF□□□C1H	EF□□□C1H

SPECIFICATIONS:

Model No. Description	EF□A/B□C1H	EF□□□C1H
Top End	Dual flange	Dual flange with 1/2"PT plug
Bottom End	Dual flange	Dual flange with 1/2"PT plug
Connecting	3/4" x10kg/cm ² (Flange)	600Lb or 300Lb
C-C Distance	Min. 150mm; Max. 5800mm	
Operation Pressure	25kg/cm ² (Max. 50kg/cm ²)	100kg/cm ² (300°C down)600Lb 60kg/cm ² (300°C up)300Lb
Operation Temp.	PP: 80°C PTFE:120°C	SUS304: 140°C SUS316: 140°C
Chamber	φ65 x 2t Coating PP or PTFE	φ 76.3 x 5.5t
Float Type	EFB-2580 (see page 9)+Coating	EFB-2654 (see page 9)
Material	SUS304 / SUS316	
Flag Indicator	EFB-0700 (200°C), EFB-0740 (400°C), EFB-0750 (140°C) (see page 10)	
Ruler	Option (see page 11)	



Nivåindikator EF Bypass

INSTALLATION

PLASTIC FLOAT SPECIFICATIONS:

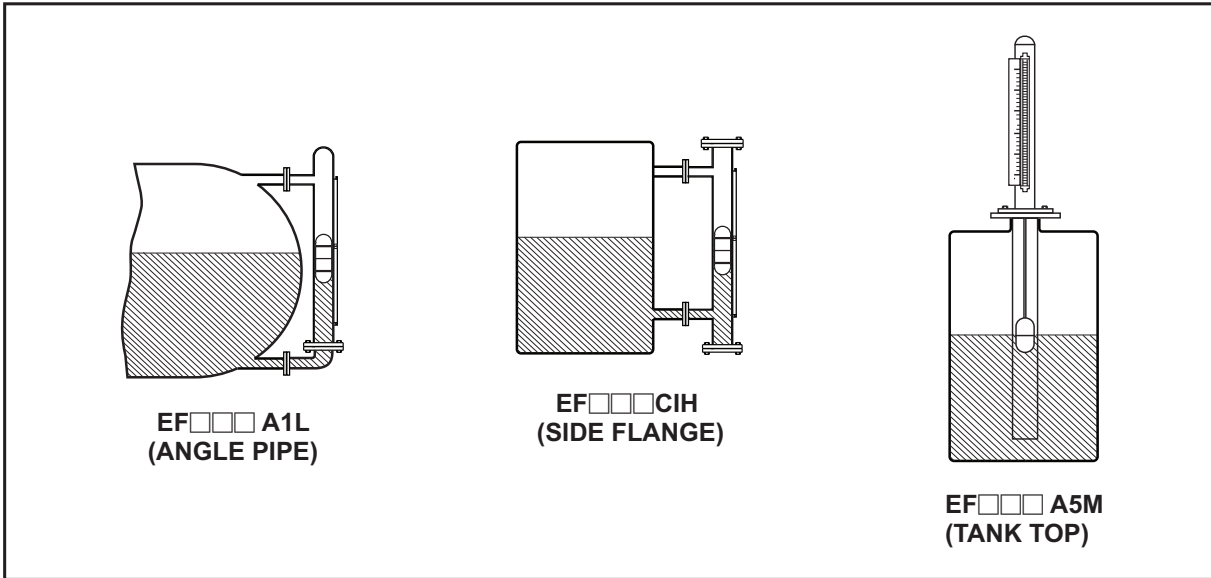

SPECIFICATIONS:

Order No.	Spec. Model No.	Operation Temp.	Max. Pressure	Dimension	S.G.	Water Immersion Line	Material	Weight
1	EFB-2500	-10~120 °C	5 kg/cm ²	φ51x168	0.75	126 mm	PVDF	256 g
2	EFB-2510	-10~80 °C	5 kg/cm ²	φ49x150	0.7	105 mm	PP	188 g

*Specified S.G. is available made to order.

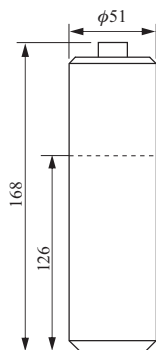

TYPE: EFB-2500 (PVDF)

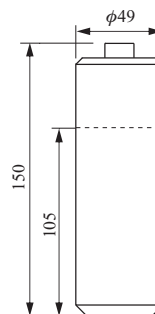

TYPE: EFB-2510 (PP)



FLOAT SPECIFICATIONS

METAL FLOAT:

Order No.	Spec. Type	Operation Temp.	Max. Pressure	Dimension	S.G.	Water Immersion Line	Material	Weight
3	EFB-2540	400°C	30 kg/cm ²	φ50x200	0.7	140 mm	SUS316	234 g
A	EFB-2560	400°C	30 kg/cm ²	φ50x175	0.75	131 mm	SUS316	220 g
C	EFB-2580	400°C	40 kg/cm ²	φ50x150	0.87	130 mm	SUS316	207 g
I	EFB-2592	200°C	60 kg/cm ²	φ50x230	0.72	166 mm	SUS316	284 g
		201°C~400°C	45 kg/cm ²					
K	EFB-2654	300°C	110 kg/cm ²	φ61.3x394	0.8	315 mm	Titanium	830 g
		301°C~400°C	90 kg/cm ²					
D	EFB-2600	400°C	40 Kg/cm ²	φ50x295	0.68	204 mm	SUS316	330 g
E	EFB-2620	400°C	15 kg/cm ²	φ50x140	0.6	84 mm	Titanium	148 g
G	EFB-2630	400°C	20 kg/cm ²	φ50x210	0.51	107 mm	Titanium	183 g

* Length of float: EFB-2600 is extendable at unit of 50 mm (S.G drops 0.05 when length increases 50 mm).

* Float can be coated with PTFE.

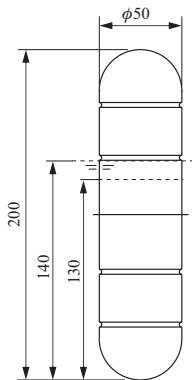

TYPE: EFB-2540

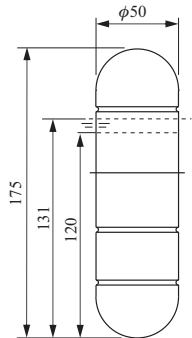

TYPE: EFB-2560

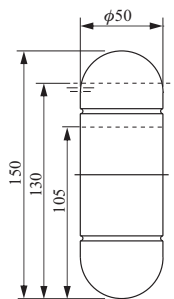

TYPE: EFB-2580

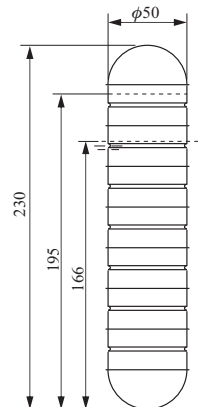

TYPE: EFB-2592

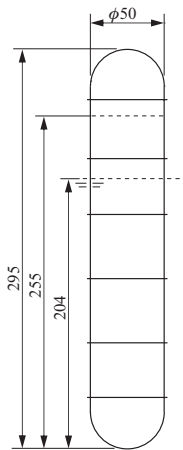

TYPE: EFB-2600

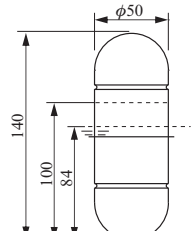

TYPE: EFB-2620

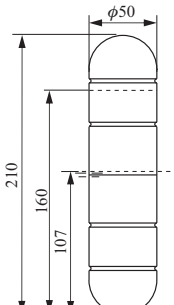

TYPE: EFB-2630

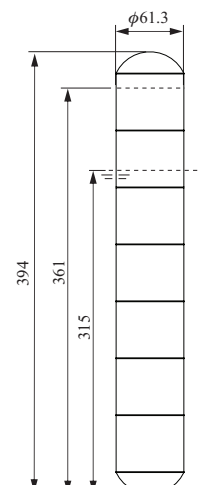

TYPE: EFB-2654

*The dotted line is the Magnet location.



FLAG DISPLAY

Model No. EFB-0750

1. Housing material : SUS 304
2. Flag Material : Engineering plastic
3. Flag Color : Red / White; Green / White
4. Cover Material : Engineering plastics
5. Operation Temp. : -20~140°C
6. Standard Unit : 50mm

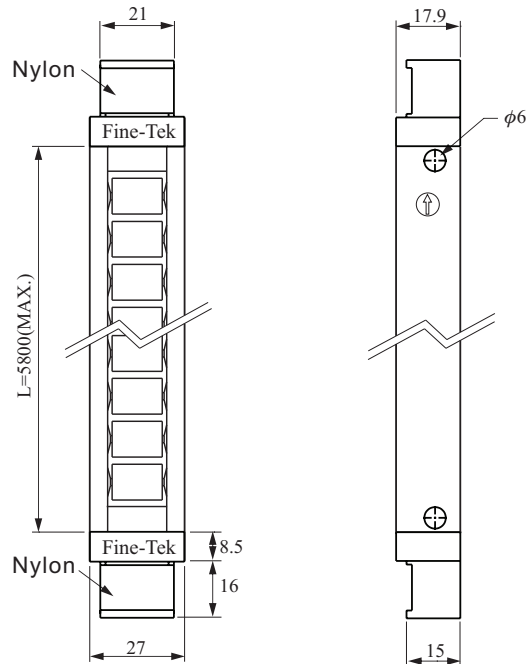

Model No. EFB-0700

1. Housing material : SUS 304
2. Flag Material : Engineering plastic
3. Flag Color : Red / White; Green / White
4. Cover Material : Engineering plastics
5. Operation Temp. : -20~200°C
6. Standard Unit : 50mm

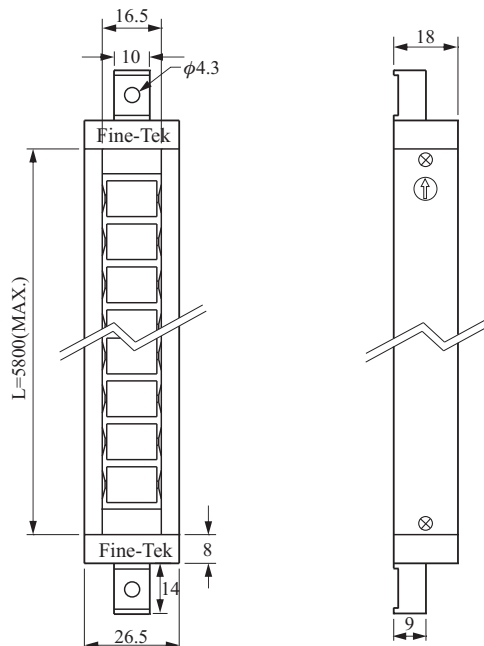

Model No. EFB-0740

1. Housing material : SUS 304
2. Flag Material : Ceramic
3. Flag Color : Red / White; Green / White
4. Cover Material : Glass
5. Operation Temp. : -20~400°C
6. Standard Unit : 50mm



RULER

Model No. EFA-2111 (unit: cm L Type)

Model No. EFA-2120 (unit: inch)

1. Dimension : 35(W)x1.5(T)xL
2. Material : SUS 304
3. Color : Black word
4. Operation Temp. : -20~400°C
5. Length : 5.8M (228")

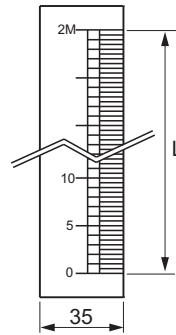

EFA-2111

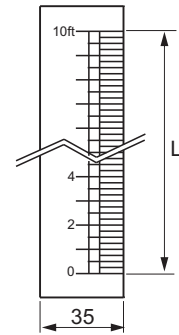

EFA-2120

Model No. EFA-2130-cm(unit: cm)

Model No. EFA-2130-in(unit: inch)

1. Dimension : 26(W)x3(T)xL
2. Material : Plastic
3. Color : Red word
4. Operation Temp. : -20~80°C
5. Length : 5.8M (228")

* Custom-made scale is available.

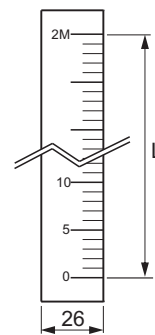

EFA-2130-cm

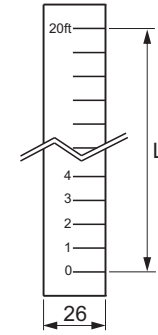

EFA-2140-in



MAGNETIC SWITCH

[ECONOMY TYPE]

Model No. EFB-1220/1230

- 1. Contact Element : Reed Switch
- 2. Switch Form : EFB-1220, SPDT Hold type
EFB-1230, SPDT Normal type
- 3. Contact Capacity : 1A /30W / 200Vdc /240Vac
- 4. Housing Material : Aluminum
- 5. Operation Temp. : -20~200°C
- 6. Protection : IP67
- 7. Cable Length : 1M (Silicon Cable)
- 8. Color code of wires: Black- COM; brown-NC; blue-NO
Yellow /green-GND

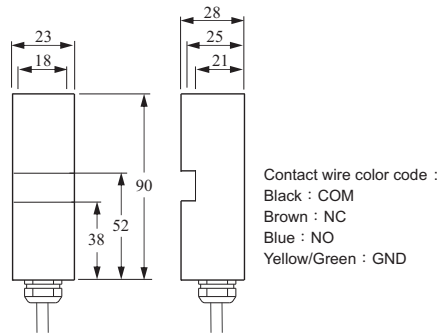

[STANDARD TYPE]

Model No. EFB-1250/1260

- 1. Contact Element : Reed switch
- 2. Switch Form : EFB-1250, SPDT Hold type
EFB-1260, SPDT Normal type
- 3. Contact Capacity : 1A /30W / 200Vdc /240Vac
- 4. Housing Material : Aluminum
- 5. Operation Temp. : -20~150°C(max. 250°C)
- 6. Protection : IP65

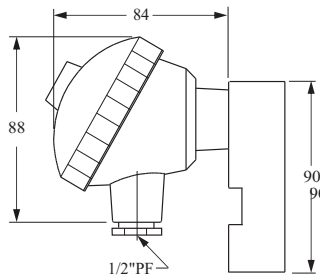

[ENCLOSURE EXPLOSION-PROOF TYPE]

Model No. EFB-1300/1310

- 1. Contact Element : Reed switch
- 2. Switch Form : EFB-1300, SPDT Hold type
EFB-1310, SPDT Normal type
- 3. Contact Rating : 1A /30W / 200Vdc /240Vac
- 4. Housing Material : Aluminum
- 5. Operation Temp. : -20~85°C (max. 250°C)
- 6. Protection : Ex d IIC T6
- 7. Explosion-proof cable conduit is optional.

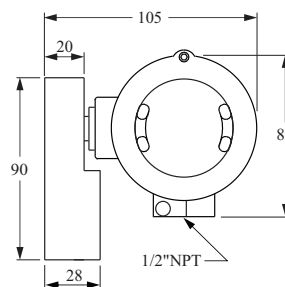

[ADJUSTABLE TYPE]

Model No. EFB-14□□

- 1. Contact Element : Reed Switch
- 2. Switch Form : EFB-1400, SPST NO Hold type
EFB-1410, SPST NO Normal type
EFB-1420, SPDT Hold type
EFB-1430, SPDT Normal type
EFB-1440, SPST NO Hold type (side lead wire)
EFB-1450, SPST NO Hold type (LED display)
- 3. Contact Rating : 1A /30W / 200Vdc /240Vac
- 4. LED Power : 24 Vdc ±20%(for EFB-1450)
- 5. Housing Material : PP
- 6. Operation Temp. : -20~140°C
- 7. Protection : IP67
- 8. Cable Length : 2M (PVC Cable)
- 9. Contact wiring :

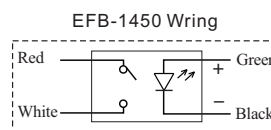
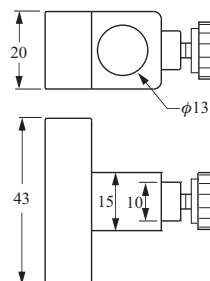

Red: COM, White: NO (EFB-1400/ 1410/ 1440 / 1450)
Black: COM, Red: NC, White: NO (EFB-1420 / 1430)

LEVEL TRANSDUCER

Model No.: FGCG□0

- Housing material : PC(IP65) 85(W)x80(H)x55(D)
- Tube : $\phi 14$ mm / $\phi 17.2$ (length over 3M)
SUS 304 or SUS 316
- Accuracy : 6.35mm
- Output : 4~20mA two-wire
- Power : 12~36Vdc
- Measuring Range : 0.15~3M / 3~5.8M ($\phi 17.2$)
- Ambient Temp. : -10~80°C
- Accuracy : $\pm 0.1\%$

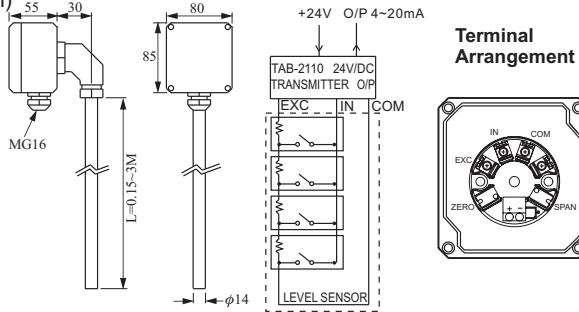

Model No.: FGCL□0

- Housing material : Aluminum EEx d IIC T6
- Tube : $\phi 14$ mm / $\phi 17.2$ (length over 3M)
SUS 304 or SUS 316
- Accuracy : 6.35mm
- Output : 4~20mA two-wire
- Power : 12~36Vdc
- Measuring Range : 0.15~3M / 3~5.8M ($\phi 17.2$)
- Ambient Temp. : -10~80°C
- Accuracy : $\pm 0.1\%$
- Explosion-proof cable conduit is optional.

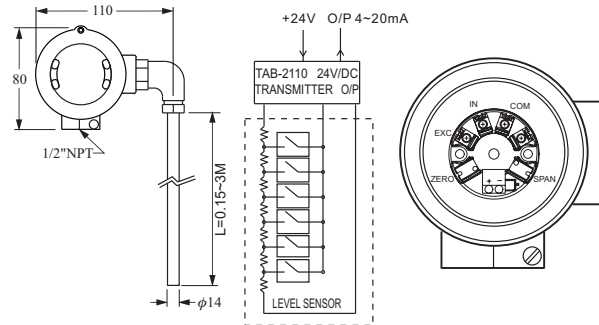

ORDER INFORMATION

FG A G 4 0

RESOLUTION

- A: 6.35mm (3-wire)
- C: 6.35mm (2-wire) with TAB-2110

TERMINAL HOUSING

- G: PC (IP65)
- K: Aluminum (EEx d IIC T6)
- L: Aluminum (EEx d IIC T6)
- N: SUS304 or 316
- X: Aluminum (IP65)

TUBE TYPE & MATERIAL

- 4: $\phi 14$ (SUS)
- 7: $\phi 17.2$ (SUS)
- 8: $\phi 20$ (PVDF)

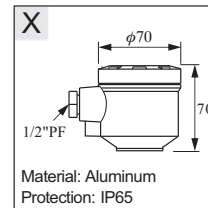
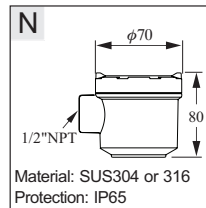
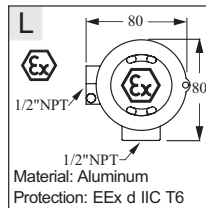
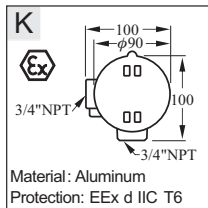
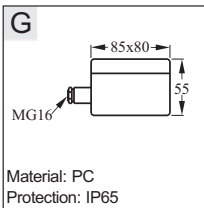



TRANSDUCER & TRANSDUCER WIRING DIAGRAMS

Model No.: TAB-2110 Transducer

Power Supply : 12~36Vdc
 Output Current : Loop power 4~20mA
 Load Resistance : $RL(Max)=50(Vs-8)$
 Operation Temperature : -40~80 °C
 Ambient Humidity : 0~80 RH
 Accuracy : $\pm 0.1\%(25^{\circ}C)$
 Temperature Effect : 0.01%F.S./°C
 Adjustment Range : Span Ajustment 20% FS
 Zero Ajustment 5% FS

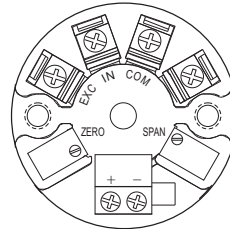

TRANSDUCER WIRING DIAGRAMS

► 2-wire level transducer (resistance output) connected with analog meter for level monitoring.

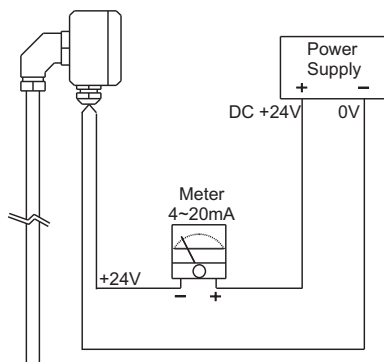

► 3-wire level transducer (4~20mA output) connected with 4~20mA analog meter for level monitoring.

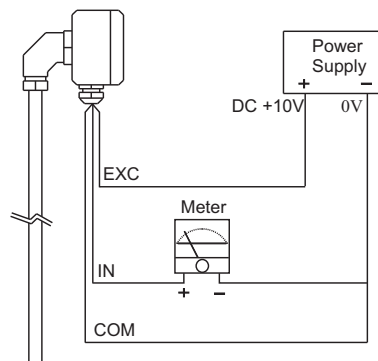

► 2-wire level transducer (4~20mA output) connected with digital meter (PB-Series) for level control.

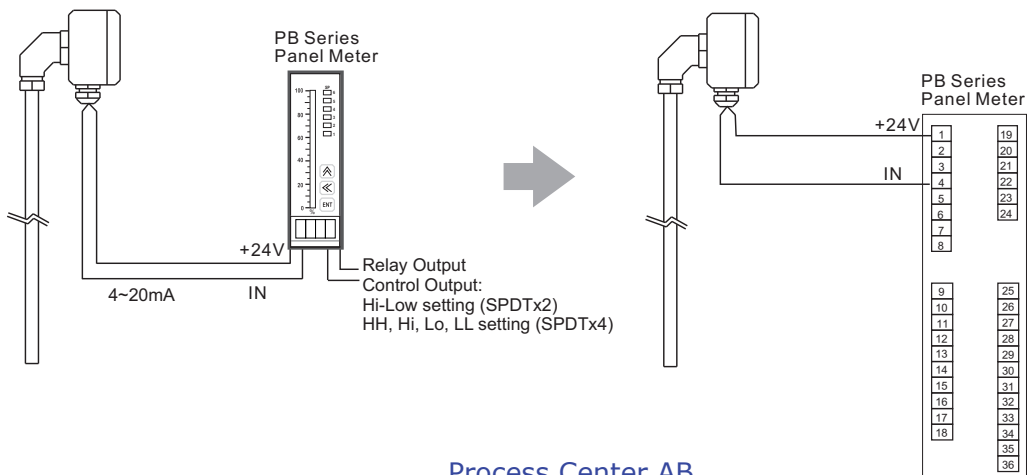



Process Center AB

Nivåindikator EF Bypass

www.processcenter.se

TRANSDUCER & TRANSDUCER WIRING DIAGRAMS

TYPE: EF+EG

1. Material : SUA304
2. Non-Linearity : $\pm 0.05\%$ F.S or $\pm 1.0\text{mm}$ (whichever is greater)
3. Repeatability : $\pm 0.01\%$ F.S或 $\pm 0.5\text{mm}$ (whichever is greater)
4. Operation Temp. : $-30^{\circ}\text{C}\sim 200^{\circ}\text{C}$
5. Output : 4~20mA
6. Communication : RS-485
7. Loop power : $+24\text{Vdc}\pm 10\%$
8. Protection : IP67

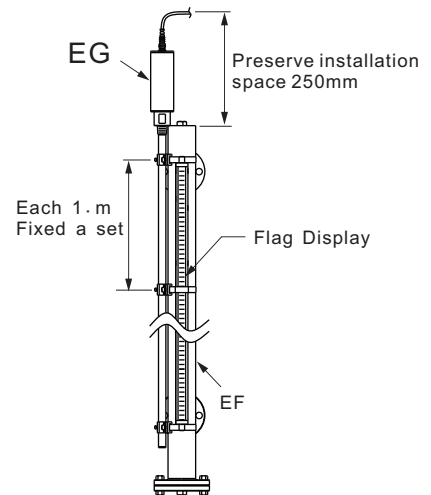

Order Information For EF+EG

During model selection of EF Series, please select EG Transmitter parts code as described below:

EF **C** **1** **1** **A1H** **1** (**J3**)-**05** ()

Transmitter

- A : EG37 Intrinsically Safe Explosion-Proof Modbus RS-485 Output
(EG371BQ00-00AB-L)
- B : EG37 Intrinsically Safe Explosion-Proof 4~20mA(Bottom~Top)Output
(EG371BQ00-00A0-L)
- C : EG37 Intrinsically Safe Explosion-Proof 4~20mA(Top~Bottom)ReverseDirection Output
(EG371BQ00-00B0-L)
- D : EG31Modbus RS-485 Output
(EG311BQ00-00AB-L)
- E : EG31 4~20mA(Bottom~Top)Output
(EG311BQ00-00A0-L)
- F : EG31 4~20mA(Top~Bottom)Reverse Direction Output
(EG311BQ00-00B0-L)

- ※ EG Transmitter is not suitable for By-Pass Indicator with Dual Flange, Blanket type, Jacket type & Removable Insulation type.
- ※ EG transmitter fastener code number : EGB-0500



Nivåindikator EF Bypass

www.processcenter.se

BALL VALVE

Model No.: LN-010

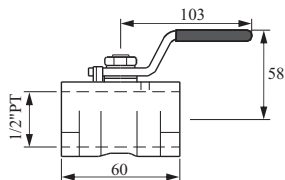

Model No.: LN-02□

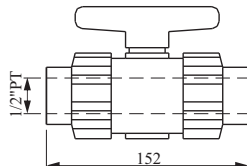

PART		LN-010	LN-021	LN-022
1	Body Material	SUS316	PP	PVDF
2	Working Temp.	150°C	80°C	120°C
3	Working Pres.	1/2"PT	1/2"PT	
4	Connection	20kg/cm ²	5kg/cm ²	

Model No.: LN-□ 30

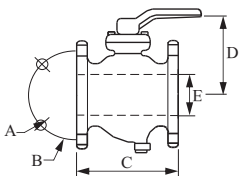

DIMENSIONS

SIZE CODE	3/4"	1"
A, B	ACCORDING TO JIS 10K	
C	120	130
D	90	90
E	21.8	25

PART		LN-□30
1	Body Material	SUS304
2	Working Temp.	150°C
3	Working Pres.	10kg/cm ²
4	Connection	LN-□ 30 2: 3/4" JIS 10K 3: 1" JIS 10K

Model No.: LN-□ 4□

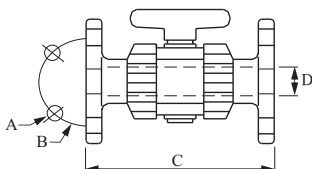

DIMENSIONS

SIZE CODE	3/4"	1"
A, B	ACCORDING TO JIS 10K	
C	172	187
D	18	23

PART		LN-□41	LN-□42
1	Body Material	PP	PVDF
2	Working Temp.	80°C	120°C
3	Working Pres.	5kg/cm ²	
4	Connection	LN-□ 49 2: 3/4" JIS 10K 3: 1" JIS 10K	

Bellows Sealed Valve

Model No.: LN-□50

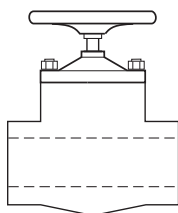

Model No.: LN-□60

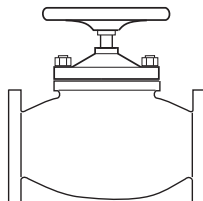

PART		LN-□50	LN-□60
1	Body Material	SUS316	SUS316
2	Working Temp.	350°C	350°C
3	Working Pres.	25kg/cm ²	25kg/cm ²
4	Connection	LN-□ 50 2: 3/4"PT 3: 1"PT	LN-□ 60 2: DN15 PN16 3: DN20 PN16



TYPICAL ASSEMBLY

1. (Fig.1) By-pass Level indicator with the standard magnetic switches (Aluminum Alloy) and liquid level transmitter. With the housing protection IP65, it is suitable for outdoor or moist environment.
2. (Fig.2) By-pass Level Indicator with explosion-proof magnetic switches. With its housing protection Ex d IIC T6, it is applicable for hazardous environments .
3. (Fig.3) By-pass Level Indicator with adjustable magnetic switches and SUS304 ruler. It can be assembled with upward /downward movable multiple magnetic switches on a riding rod.

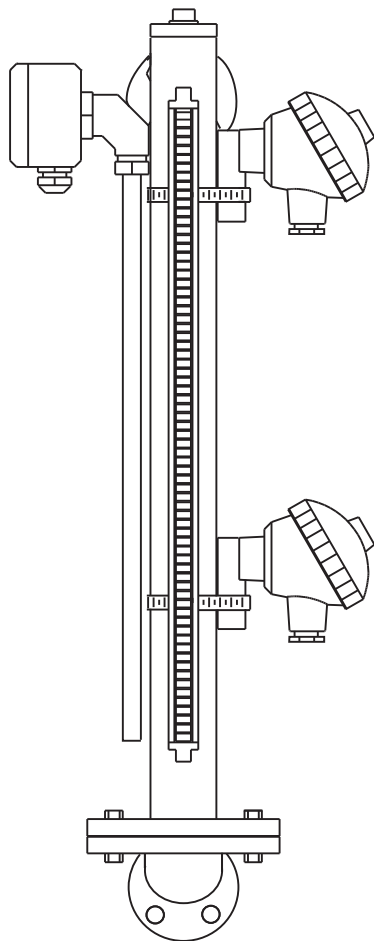

fig. 1

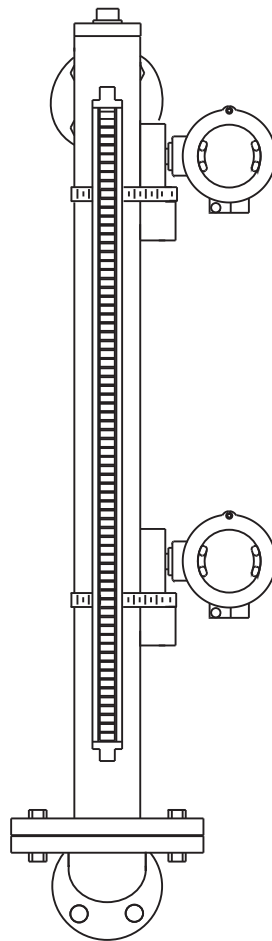

fig. 2

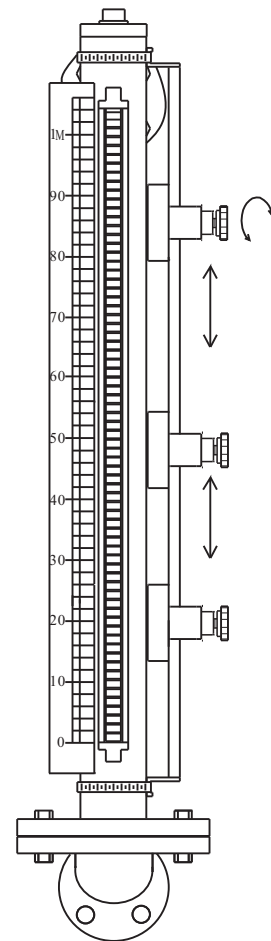

fig. 3



CAUTIONS FOR INSTALLATION

1. The magnetic switch (EFB-14□□ series) is to be placed on a riding rod, then fasten the riding rod to the chamber with two hose clamps. (see page 18 - fig.3)
2. The magnetic switch (EFB-12□□ & EFB-13□□) is to be fastened on the chamber with a hose clamp. (see fig.4 and page 18 - fig.1, fig.2) Positioning orientation of magnetic switches as fig.2.
3. Because the magnetic switch is a sensitive component, thus any extreme shock to the switch will cause malfunction.
4. Make sure there is no external magnetic field or source within 10 centimeters of the switch to avoid magnetic interference.
5. Make sure the wire of the magnetic switch is pointing downward.
6. Do not contact any high temperature material with unit's cables while wiring.
7. When using magnetic switch to control inductive or capacitive load, a RC protective circuit should be used to ensure long life of the switch contact.
8. The magnetic switch must be located near the flag display and the surface of it is as close to the outer chamber wall as possible.
9. Before actuating, be sure all wirings are done correctly.
10. See fig.3 for the installation direction of mounting holes
11. A fixed holder is recommended to be used in between center to center flanges when distance is beyond 1.5 meters. Maximum distance between two fixed holders or center flange to fixed holder can not exceed 1 meter for best stability. Fixed holders will be a custom-made accessory for different applications. To order, please fill out the request in order form as shown in fig 7.

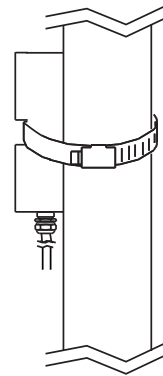

fig. 4

Position Orientation Of Magnetic Switches

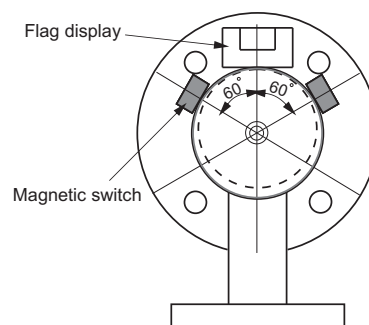

fig. 5

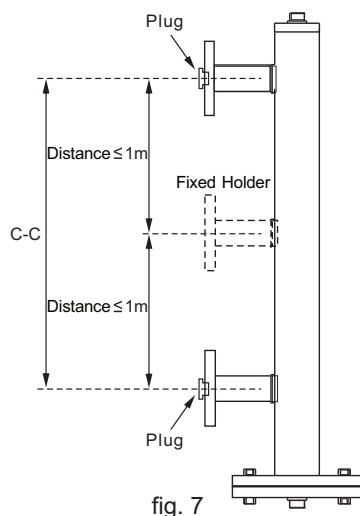

fig. 7

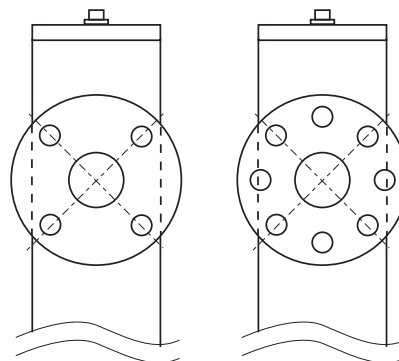

fig. 6







Nivåindikator EF Bypass



www.processcenter.se

ORDER INFORMATION

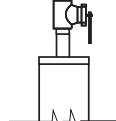
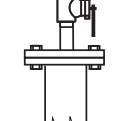
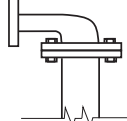
Top End Type

A Cap	B Flat top +Plug	C Dual flange +Plug	D Flat top +Top mounting flange
			
E Dual flange +Top mounting flange	F Flat top +Control valve	G Dual flange +Control valve	N Dual flange +Angle pipe
			

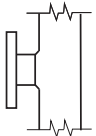
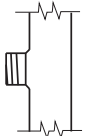
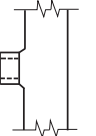
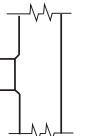
Connection

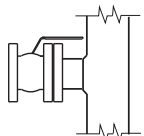
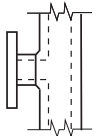
1 Flange	2 Screw (bolt type)	3 Screw (nut type)	4 Slip pipe	5 N/A	7 Control valve	8 Jacket
						

Bottom End Type

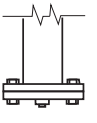
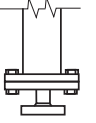
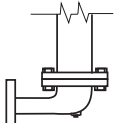
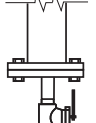
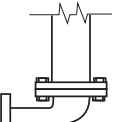
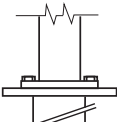
H Dual flange+Plug	I Dual flange +Top mounting flange	J Dual flange +Angle pipe+Plug	K Dual flange +Control valve
			
L Dual flange +Angle pipe	M Dual flange +Top mounting pipe		
			



HOW TO MAKE YOUR ORDER

Order No. EF C 1 1 A 1 H 1 (J 3) - 0 5 () ()

Float type (see page 8, 9)

- 1: EFB-2500 (PVDF) D: EFB-2600 (SUS316)
2: EFB-2510 (PP) E: EFB-2620 (TITANIUM)
3: EFB-2540 (SUS316) G: EFB-2630 (TITANIUM)
A: EFB-2560 (SUS316) I : EFB-2592 (SUS316)
C: EFB-2580 (SUS316) K: EFB-2654 (TITANIUM)
S: Others -: None

Material

- 1: SUS304 -- 140°C 8: SUS304 -- 200°C
2: SUS304 -- 400°C (350°C) 9: SUS316 -- 200°C
3: SUS316 -- 140°C A: PP Coating -- 80°C
4: SUS316 -- 400°C (350°C) B: PTFE Coating -- 120°C
6: PP -- 80°C C: Blanket -- 400°C
7: PVDF -- 120°C D: Heating Type -- 100°C
*(350°C) with valve
*EG Transmitter is not suitable to use with Blanket type, Jacket type & Removable Insulation type.

Flag Display (see page 10)

- 1: EFB - 0750 (-20~140°C) 5: EFB - 0740 (-20~400°C)
6: EFB - 0700 (-20~200°C) 9: Other -: None

End / Connection type (see page 20)

Top end Type

- A: Cap
B: Flat top+Plug
C: Dual flange+Plug
D: Flat top +Top mounting flange
E: Dual flange +Top mounting flange
F : Flat top+Control valve
G: Dual flange+Control valve
N: Dual flange+angle pipe
S: other

Connection

- 1: Flange
2: Screw (bolt type)
3: Screw (nut type)
4: Slip pipe
5: N/A
7: Control valve
8: Jacket
S: other

Bottom end Type

- H : Dual flange+Plug
I : Dual flange +Top mounting flange
J : Dual flange+angel pipe +Plug
K : Dual flange+control valve
L : Dual flange+angle pipe
M: Dual flange +Top mounting pipe
S: other

* EG Transmitter can't apply with dual flange at the same time which be installed double end of EG .

Operating Pressure range

- 1: -1~ 10kg/cm² 2: -1~ 25kg/cm² 3: -1~ 50kg/cm²
4: -1~100kg/cm² 5: 0~5kg/cm² (Plastic)

Magnetic Switch (see page 12) Quantity 1~ 4

- A: EFB -1220 D: EFB-1260 G: EFB-1400 J : EFB-1430 M: EFB-1350
B: EFB -1230 E: EFB -1300 H: EFB -1410 K: EFB -1450 N: EFB -1360
C: EFB-1250 F : EFB -1310 I : EFB-1420 L: EFB -1440

*Omit these two codes if no magnetic switch required.

Length (Unit: m)

- 05: below 0.5m 10: 0.5~1m 15: 1~1.5m . . . *0.5m per Unit

Transducer

- a. If transmitter is not required, please omit this item.
b. If EG transmitter is selected, model (A,B,C,D,E,F) are available
c. If FG transmitter is selected, model (G,K,L,N,X) are available

*Blanket type, Jacket type and Removable insulation type can't match EG transmitter.

Ruler

Metal: M Plastic: P *Omit this code if no ruler required.

*Special term for LR Marine approval: "Environmental test has been carried out but it is not applicable to use in the ship and offshore that type of screw fittings is used for pipe exceeding 51mm outer diameter".