



Manual Konduktivetsmätare DDG-2080x

www.processcenter.se





Manual Konduktivitetmätare DDG-2080x

www.processcenter.se

Content

Safe operation procedures-----	2
Instrument use-----	2
Product content-----	2
Specifications-----	3
Instrument installation-----	4
Connection label-----	7
Electrode connection figure-----	7
Relay contact protection -----	10
Display -----	11
Key-----	13
Keeping mode-----	13
Setting-----	13
Current 1 settings-----	14
Current 2 settings-----	14
Relay 1 settings-----	14
Relay 2 settings-----	15
Relay 3 settings-----	15
Measuring settings-----	16
Temperature settings-----	16
RS485 settings-----	17
Date settings-----	17
Data log settings-----	17
Output test-----	18
Language Settings-----	18
Reset parameters-----	18
Record query-----	19
EC calibration-----	19
Default-----	21
Password-----	23
Error code-----	23
RS485 command-----	23



Manual Konduktivitetmätare DDG-2080x

www.processcenter.se

Safe operation procedures

Read the following instructions before using the instrument.

1. After unpacking the instrument please check for damage due to shipping.
2. The instrument must be operated by trained professional and technical personnel.
3. Read the manual carefully to avoid incorrect wiring connection that can cause equipment damage and safe problem.
4. After wiring carefully check all are correct then can power on and make sure the others equipment are correct.
5. Please avoid installing in a high humidity, high temperature, corrosive and in a direct sunlight environment.
6. Please separate the power lines of instrument from other machines that produces high noise in the power lines.

Instrument use

Instruments are used in industrial measuring of the temperature, conductivity, Resistivity, salinity and total dissolved solids, such as waste water treatment, environmental monitoring, pure water, sea farming, food production process, etc.

The instrument can be panel, wall or pipe mounted.

The instrument provides two current outputs. The maximum load is 500 Ohm.

The instrument provides 3 relays. It can pass though a maximum of 5 Amps at 250 VAC or 5 Amps at 30VDC.

Product content

the product package contains 1 instrument, the printed manual, 4 sets of holder.(fixed block, fixed bar, screw)



Manual Konduktivetsmätare DDG-2080x

www.processcenter.se

Specifications

Functions	EC	Resistivity	Salinity	TDS
Measuring range	0.00uS-200 0mS	0.00-20.00 MΩ-CM	0.00-78.00 g/Kg	0-133000 ppm
Resolution	0.01/0.1/1	0.01	0.01	1
Accuracy	±1%F.S.	±1%F.S.	±1%F.S.	±1%F.S.
Temp. compensation	Pt 1000/NTC30K			
Temp. range	-10.0 to +130.0°C			
Temp. compensation range	-10.0 to +130.0°C			
Temp. resolution	0.1°C			
Temp. accuracy	±0.2°C			
Cell constant	0.001 to 20.000			
Ambient temperature range	0 to +70°C			
Storage temp.	-20 to +70°C			
Display	Back light, dot matrix			
EC current output1	Isolated, 4 to 20mA output , max. load 500Ω			
Temp. current output 2	Isolated, 4 to 20mA output , max. load 500Ω			
Current output accuracy	±0.05 mA			
RS485	Mod bus RTU protocol			
Baud rate	9600/19200/38400			
Maximum relay contacts capacity	5A/250VAC,5A/30VDC			
Cleaning setting	ON: 1 to 1000 seconds, OFF: 0.1 to 1000.0 hours			
One multi function relay	clean/period alarm/error alarm			
Relay delay	0-120 seconds			
Data logging capacity	500,000			
Language selection	English/traditional Chinese/simplified Chinese			
Waterproof grade	IP65			
Power supply	From 90 to 260 VAC, power consumption < 5 watts			
Installation	panel/wall/pipe installation			
Weight	0.85Kg			

Manual Konduktivitetmätare DDG-2080x

www.processcenter.se

Instrument installation

The instrument can be panel, wall or pipe mounted installation.

Panel Installation: Make a 138x138 mm square cutout and insert the instrument. Screw in the fixed block with the screws and fixed bar.

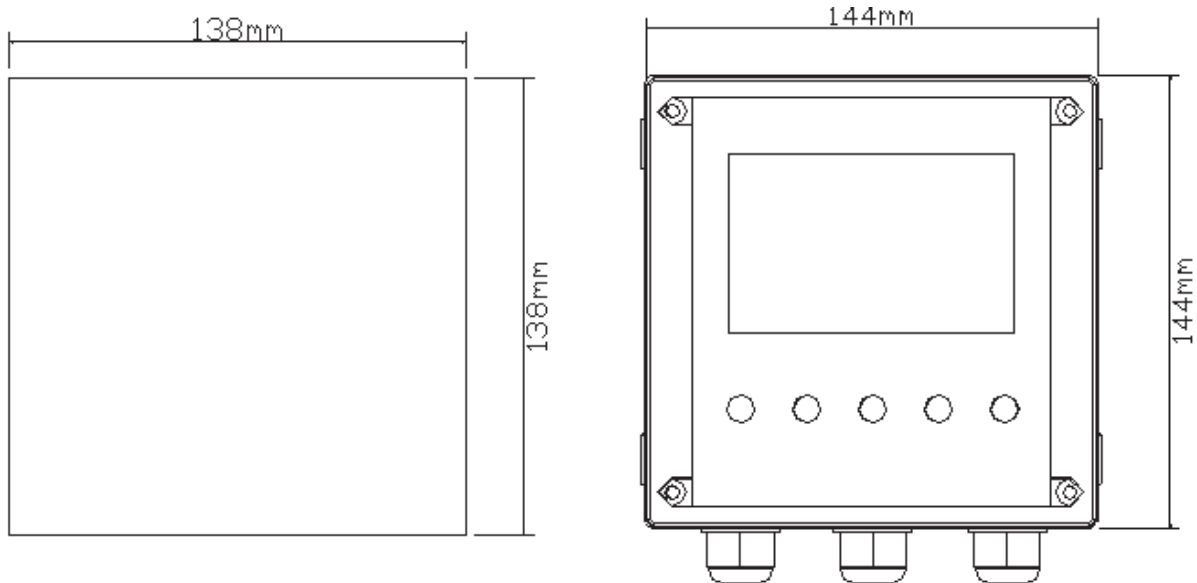

cutout size

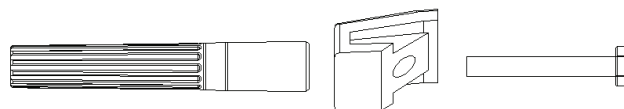
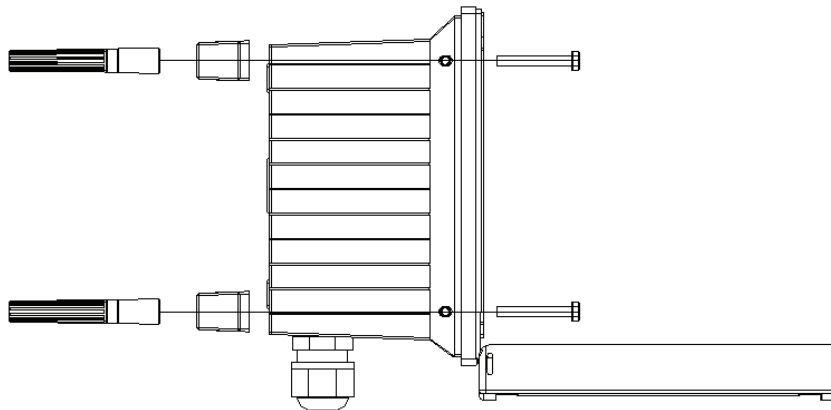

installation figure

Manual Konduktivitetmätare DDG-2080x

www.processcenter.se

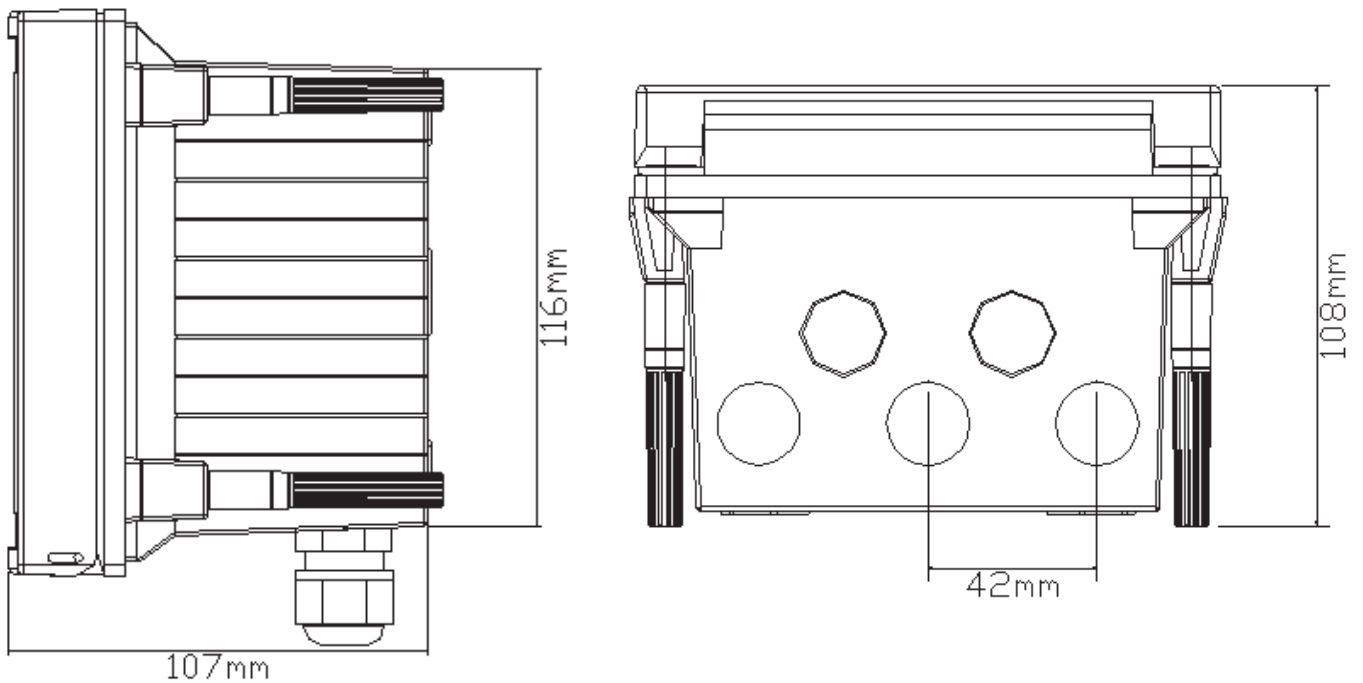

dimension

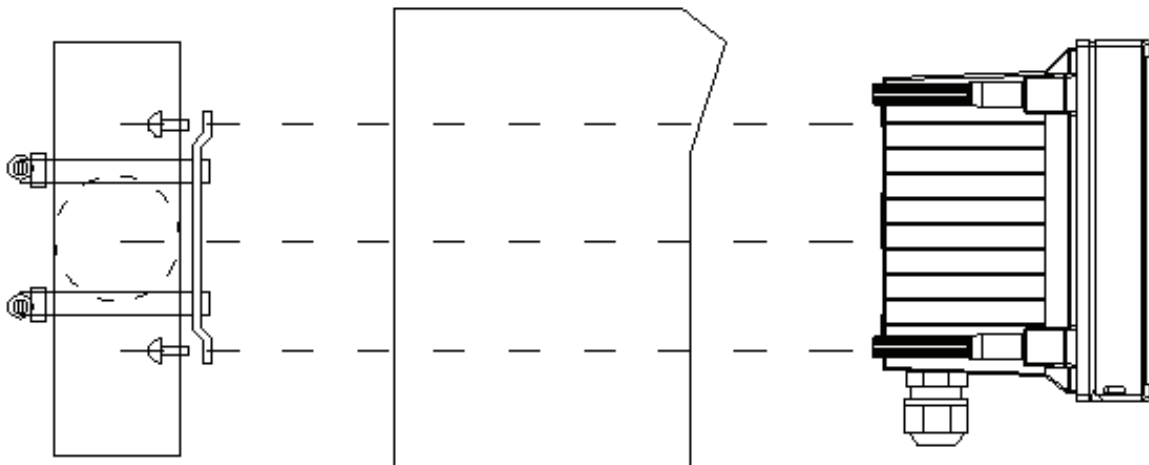

wall and pipe installation



Manual Konduktivitetsmätare DDG-2080x

www.processcenter.se

Connection label

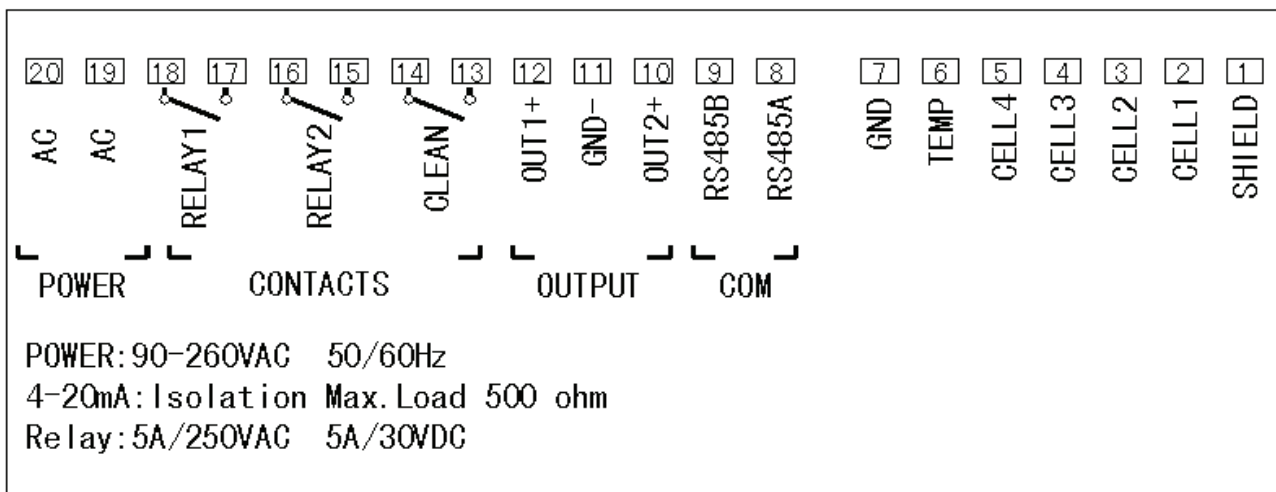

Electrode connection figure

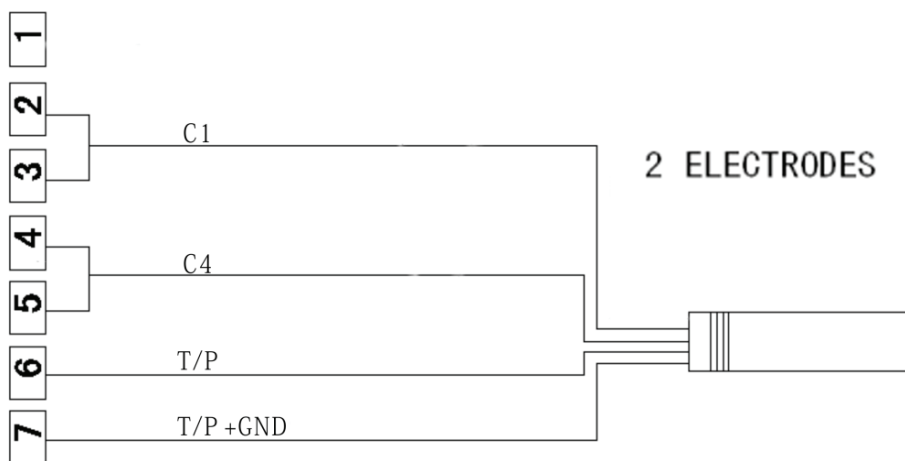
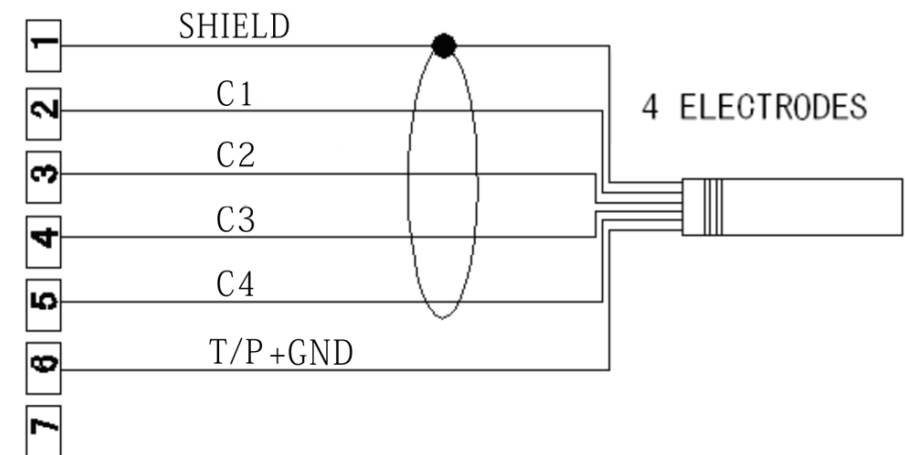

Manual Konduktivitetsmätare DDG-2080x

www.processcenter.se

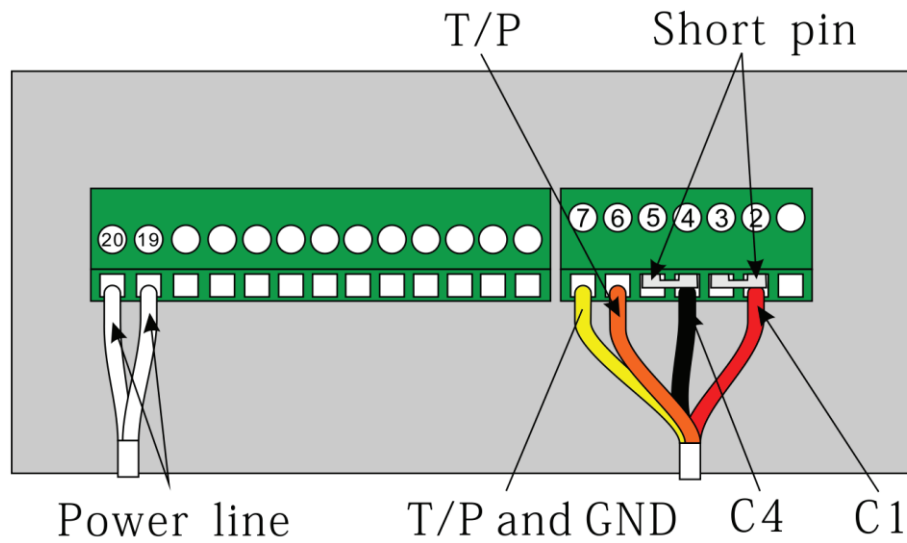
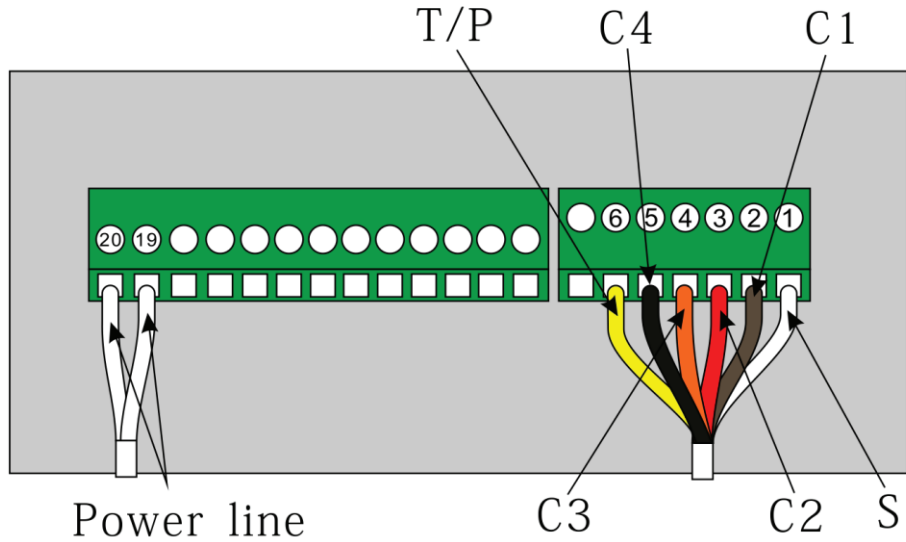



Manual Konduktivitetsmätare DDG-2080x

www.processcenter.se

Electrode connection figure

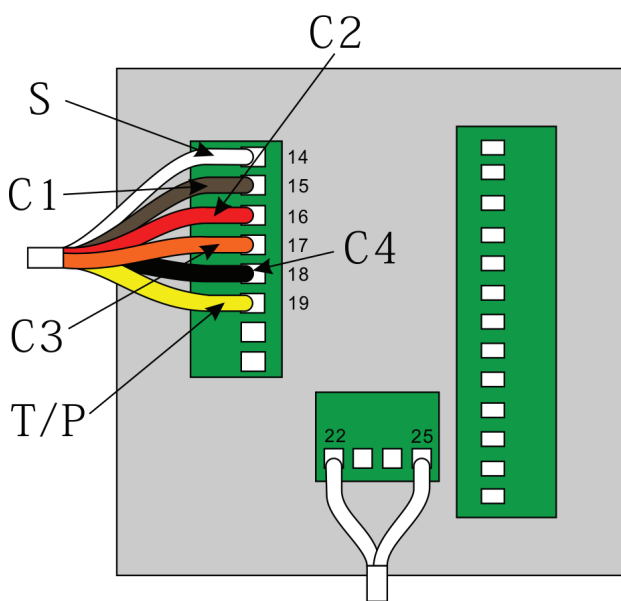
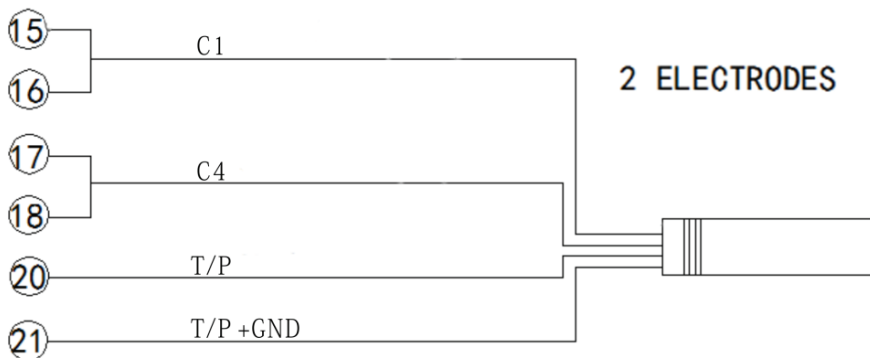
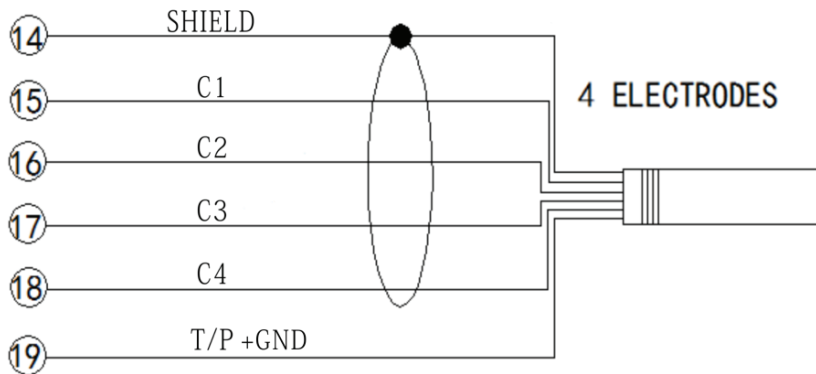

Power line

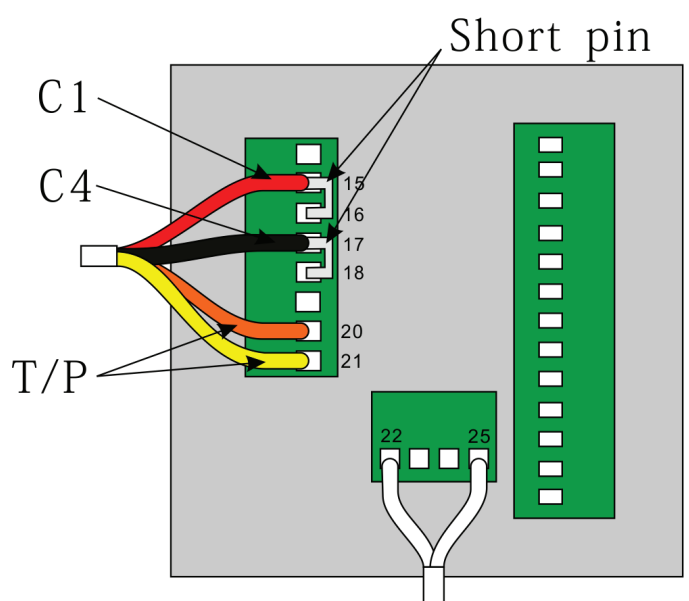

Power line

Manual Konduktivetsmätare DDG-2080x

www.processcenter.se

Relay contact protection

Electrical spark at the relay contact may affect the life of the relay, especially in an inductive and capacitive load. In order to inhibit the spark and arc, user should use an RC circuit to extend the life of the relay.

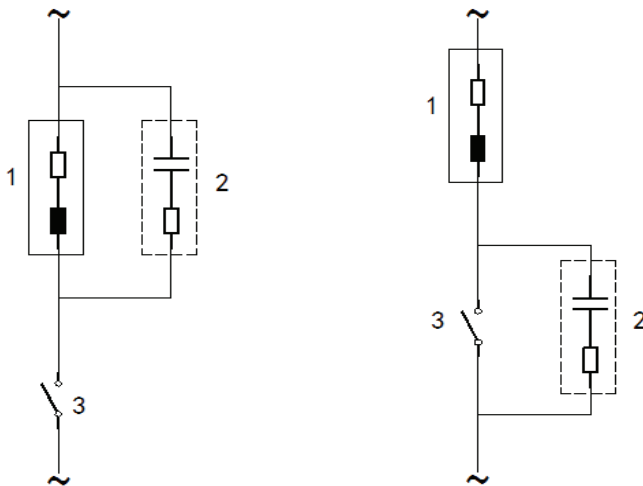

AC protection, use for inductive load

1. load
2. RC eliminate spark, using in 220VAC, R=100 ohm1W,
3. Relay contact

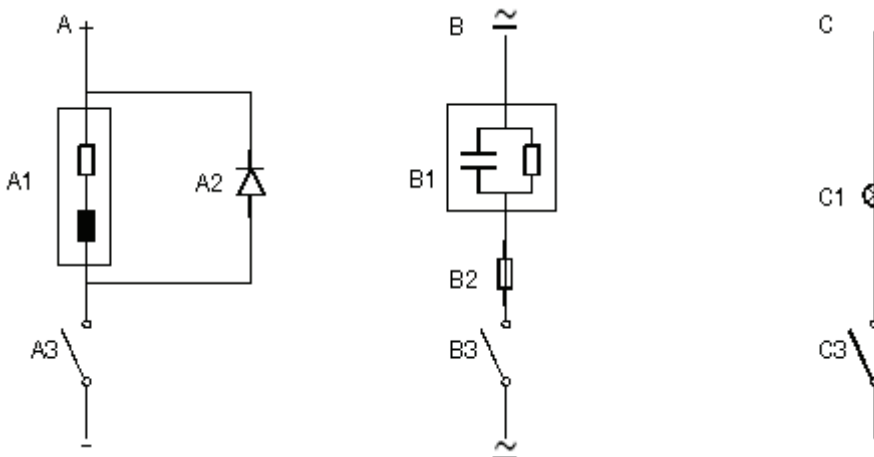

- A. DC protection ,A1: inductive load A2: 1N4007, A3: relay contact
- B. AC/DC protection ,B1: capacitive load ,B2: 0.8 Ohm/1W (DC24V) ,B3: relay contact
- C. Resistive load ,C1:lamp bulb ,C3:relay contact

Manual Konduktivitetsmätare DDG-2080x

www.processcenter.se

Display

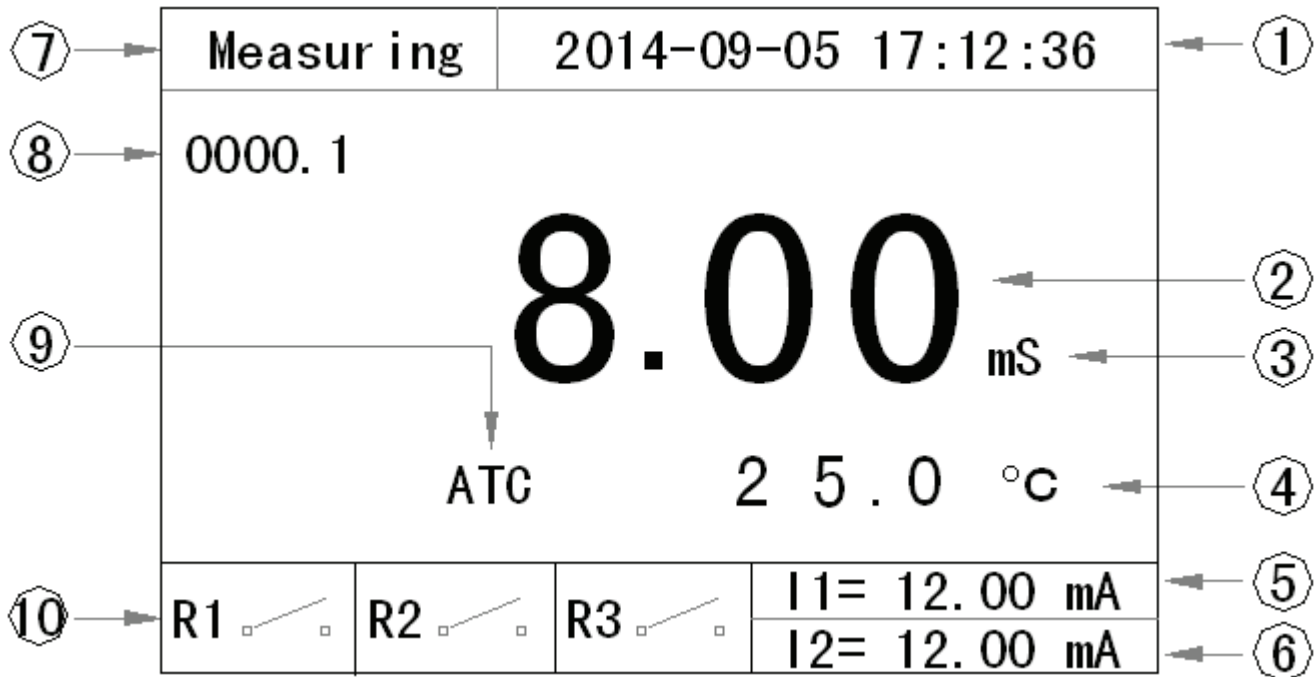

1. Date and time
2. Main display
3. Unit
4. Temperature and unit
5. First current output
6. Second current output
7. Measurement status and Error indicator, there is no display if meter is in keeping mode
8. Count down timer: cycle time/clean time, it also displays the "delay" when relay3 has a delay enabled.
9. Temp. compensation: auto(ATC) or manual(MTC)
10. Relay indicator

Note:

If the EC readings are over the range, it will display 99.99/999.9/9999

If the temperature readings are under or over the range, it will display -99.9/999.9.

Manual Konduktivitetmätare DDG-2080x

www.processcenter.se

Key



MODE



SHIFT



UP



DOWN

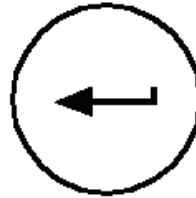

ENTER

Key name	Meas. status	Setting status	Cal. status	Record status
MODE	Enter password	Exit	Exit	Exit
SHIFT	none	Move digit	Mode digit	Mode digit
UP	Enter record	Inc	Inc	Inc
DOWN	None	Dec	Dec	Dec
ENTER	ON/OFF back light	Enter	Enter	Enter

Keeping mode

Keeping mode is a safe mode. It is for Calibration, Setting, Record and Clean. In this mode all the relays are open(inactive), current output follows the setting by user(last current or fixed current).

The instrument will enter keeping mode when user presses into Calibration, Setting, Record or the instrument works in clean mode.

It will in keeping mode around 10 seconds when it goes back to measurement mode form the above mentioned 4 modes then left keeping mode.

The instrument will go into the keeping mode when turn on the power.

Current output in keeping mode:

User has two choices: fixed current output or last current output.

Fixed current: User can set the output current from 4.00 to 20.00mA when instrument goes into keeping mode.

Last current: User can set the output current keep at the last current when instrument goes into keeping mode.

Relays in keeping mode: All relays are opened.(inactive)



Manual Konduktivitetsmätare DDG-2080x

www.processcenter.se

Setting

Press MODE key to enter the password menu and then press UP/DOWN/SHIFT key to input password 1200 then press ENTER will enter to setting mode or press MODE key to exit. If no key is be pressed and over 10 minutes then it will go back to measurement mode.

PASSWORD
0 0 0 0

PASSWORD
1 2 0 0

Main display

Press UP/DOWN key to choose functions, press ENTER key enter the function.

CONF IGURATION
<input checked="" type="checkbox"/> Current1 Settings
<input type="checkbox"/> Current2 Settings
<input type="checkbox"/> Relay1 Settings
<input type="checkbox"/> Relay2 Settings
<input type="checkbox"/> Relay3 Settings
<input type="checkbox"/> Measurement Settings
<input type="checkbox"/> Temperature Settings
<input type="checkbox"/> RS485 Settings

Page1

CONF IGURATION
<input checked="" type="checkbox"/> Date Settings
<input type="checkbox"/> Data Log Settings
<input type="checkbox"/> Output Test
<input type="checkbox"/> Language Settings
<input type="checkbox"/> Reset Parameters

Page2

Notices:

1. When the input data is not in correct range then it will display ERROR on the top of LCD
2. After input data user needs to press ENTER to save the data.
3. Press MODE to exit.
4. No key is be pressed in 10 minutes then it will go back to measurement mode.



Manual Konduktivitetsmätare DDG-2080x

www.processcenter.se

Current 1 settings

CURRENT 1 SETTINGS	
4.00 mA	= 0 0 0 0 uS
20.00 mA	= 1 0 0 0 uS
Offset	= + 0 . 0 0 mA
Filter Time	= 0 0 0 SEC
HOLD Type	= <input type="checkbox"/> Fixed 0 4 . 0 0 mA <input type="checkbox"/> Last

1. Set the corresponding 4.00mA to EC/ Resistivity/Salinity/TDS.
2. Set the corresponding 20.00mA to EC/ Resistivity/Salinity/TDS, the difference between 4.00mA and 20.00 mA at least for EC is 1.00/10.0/100(according to the range), for Resistivity is 1.00,for Salinity is 1.00,for TDS is 100.
3. Set the offset current ,the range is ± 1.00 mA.

4. The filter time range is 0-120 seconds, the low pass filter of software will active when the current from one point to another point if user sets the filter time.
5. Set the current 1 output mode(fixed / last) when instrument enter into keeping mode.

Current 2 settings

CURRENT 2 SETTINGS	
4.00 mA	= + 0 0 0 . 0 °C
20.00 mA	= + 1 0 0 . 0 °C
Offset	= + 0 . 0 0 mA
Filter Time	= 0 0 0 SEC
HOLD Type	= <input type="checkbox"/> Fixed 0 4 . 0 0 mA <input type="checkbox"/> Last

1. Set the corresponding 4.00mA to temperature.
2. Set the corresponding 20.00mA to temperature, the difference at least between 4.00mA and 20.00 mA is 10.0°C.
3. Set the offset current of temperature, the range is ± 1.00 mA.
4. The filter time range is 0-120 seconds, the low pass filter of software will active when the current from one point to another point if user sets the filter time.

5. Set the current 2 output mode(fixed / last) when instrument enter into keeping mode.

Relay 1 settings

RELAY 1 SETTINGS	
ON/OFF	= <input checked="" type="checkbox"/> ON <input type="checkbox"/> OFF
Close S. P.	= 1 0 0 0 uS
Open S. P.	= 0 4 0 0 uS
Delay Time	= 0 0 0 SEC

1. Press UP/DOWN key to ON/OFF (enable/disable) relay1.
2. Close set point: active point for EC/ Resistivity/Salinity/TDS.
3. Open set point: inactive point for EC/ Resistivity/Salinity/TDS.
4. Delay time: the range is 0-120 seconds. Relay needs to delay first then active if the measuring data is reach to close set point.

Ex: If user wants turn on the pump at EC

1000uS and turn off it at EC 400uS, then the close S.P. needs to set to 1000uS, Open S.P. sets to 400uS.



Manual Konduktivitetsmätare DDG-2080x

Relay 2 settings

RELAY 2 SETTINGS	
ON/OFF	= <input checked="" type="checkbox"/> ON <input type="checkbox"/> OFF
Close S. P.	= 0 4 0 0 μ S
Open S. P.	= 1 0 0 0 μ S
Delay Time	= 0 0 0 SEC

1. Press UP/DOWN key to ON/OFF (enable/disable) relay2.
2. Close set point: active point for EC/Resistivity/Salinity/TDS.
3. Open set point: inactive point for EC/Resistivity/Salinity/TDS.
4. Delay time: the range is 0-120 seconds. Relay needs to delay first then active if the measuring data is reach to close set point.

Ex: If user wants turn on the pump at EC400 μ S and turn off it at EC 1000 μ S, then the close S.P. needs to set to 400 μ S, Open S.P. sets to 1000 μ S.

Relay 3 settings

RELAY 3 SETTINGS	
ON/OFF	= <input checked="" type="checkbox"/> ON <input type="checkbox"/> OFF
Period Time	= 0 0 0 1 . 0 HOUR
Clean Time	= 0 0 1 0 SEC
Delay Time	= 0 0 0 SEC
Function	= <input type="checkbox"/> Rinsing <input type="checkbox"/> Interval Alarm <input type="checkbox"/> Error Alarm

1. Press UP/DOWN key to ON/OFF (enable/disable) relay3.
2. Period time: The period for Rinsing or interval function.
3. Clean time: When period is timeout then relay active.
4. Delay time: the range is 0-120 seconds. Relay needs to delay first then active if the period is timeout.

5. Function: Press UP/DOWN key to choose Rinsing/Interval/Error.

Notice:

1. Rinsing: when period timeout then clean-relay will active, when clean time is timeout the repeat count for the period.
2. Interval alarm: When period timeout then clean-relay active until user resets the interval then the clean-relay inactive and repeat count for the period.
3. Error alarm: The clean-relay active when there is a error produce. No delay time function in this mode.



Manual Konduktivitetsmätare DDG-2080x

Measurement settings

MEASUREMENT SETTINGS	
Mode	= <input checked="" type="checkbox"/> Conductivity <input type="checkbox"/> MΩ-CM <input type="checkbox"/> Salinity <input type="checkbox"/> TDS

MEASUREMENT SETTINGS	
Range	= <input type="checkbox"/> 20.00 uS <input type="checkbox"/> 200.0 uS <input checked="" type="checkbox"/> 2000 uS <input type="checkbox"/> 20.00 mS <input type="checkbox"/> 200.0 mS <input type="checkbox"/> 2000 mS
Offset	= + 0 0 0 uS
Filter	= 0 1

1. Choose the mode for measuring, press UP/DOWN key to choose, press ENTER to next.
2. The Range selection for EC only.
3. Offset , range for EC is ±1.00uS/ ±10.0uS/ ±100uS/ ±1.00mS/ ±10.0mS/ ±100mS,for Resistivity is ±1.00MΩ,for Salinity is ±1.00g/Kg, for TDS is ±100ppm
4. Filter: Range 0-10.

Notice : If the reading is not stable then user can set the filter to average the readings.

Temperature settings

TEMPERATURE SETTINGS	
Automatic	= <input checked="" type="checkbox"/> Auto <input type="checkbox"/> Manual
Probe	= <input type="checkbox"/> Pt 1000 <input type="checkbox"/> NTC 30K
Offset	= + 0 . 0 °C
Manual Meas.	= + 0 2 5 . 0 °C
Manual Cal.	= 2 5 . 0 °C

1. Temperature compensation setting, press UP/DOWN key to choose.
2. Temperature probe, press UP/DOWN key to choose.
3. Temperature offset ,the range is ±5.00°C.
4. Temperature for measuring when user set the temperature to manual.
5. Temperature for calibration mode when user sets the temperature to manual.
6. Temperature display: display the temperature on measurement mode or not.

Notice:

1. When user chooses AUTO and doesn't connect temperature probe then the display will not correct.
2. When select the probe needs to make sure the probe type is correct.
3. Manual measurement: the instrument will use this temperature for compensation in measurement mode when user chooses Manual.

4. Manual calibration: the instrument will use this temperature for compensation in



Manual Konduktivitetmätare DDG-2080x

www.processcenter.se

calibration mode when user chooses Manual.

RS485 settings

RS485 SETTINGS	
ID Address	= 0 0 1
Baud Rate	= <input type="checkbox"/> 9600
	= <input type="checkbox"/> 19200
	= <input type="checkbox"/> 38400

1. ID address:1-255.
2. Baud rate ,press UP/DOWN key to choose.

Date settings

DATE SETTINGS	
Year	= 2 0 1 5
Month	= 0 8
Day	= 1 5
Hour	= 1 3
Minute	= 3 6
Second	= 0 4

Press UP/DOWN key to set the date. When power off the date will be kept for around 2 days.

Data log settings

DATE LOG SETTINGS	
ON/OFF	= <input checked="" type="checkbox"/> ON <input type="checkbox"/> OFF
Display Type	= <input type="checkbox"/> Record <input type="checkbox"/> XY Chart
Reset Record	= <input type="checkbox"/> Yes <input type="checkbox"/> No
Save Period	= 0 6 0 SEC

1. Press UP/DOWN key to ON/OFF (enable/disable) this function.
2. Display type, press UP/DOWN key to choose
3. Erase all the records.
4. Saving period from 5 to 120 second.

Notice:

1. When user chooses ON, then it will save measuring data follow the save period time.
2. Display type: Record, display the detail of record(5 records in one page), XY chart, display a chart.(150 records in one page)
3. When reset the records, it will spend around 10 seconds.

Manual Konduktivitetmätare DDG-2080x

www.processcenter.se

Output test

OUTPUT TEST	
Current1	= 0 4 . 0 0 mA
Current2	= 0 4 . 0 0 mA
Relay1	= <input type="checkbox"/> CLOSE <input type="checkbox"/> OPEN
Relay2	= <input type="checkbox"/> CLOSE <input type="checkbox"/> OPEN
Relay3	= <input type="checkbox"/> CLOSE <input type="checkbox"/> OPEN

1. Current 1 output: 4.00-20.00mA, press UP/DOWN to set.
2. Current 2 output: 4.00-20.00mA, press UP/DOWN to set.
3. Relay 1 output, press UP/DOWN to choose.
4. Relay 2 output, press UP/DOWN to choose.
5. Relay 3 output, press UP/DOWN to choose.

Notice: This function for testing the output only.

Language settings

LANGUAGE SETTINGS	
Language	= <input checked="" type="checkbox"/> English <input type="checkbox"/> 繁體中文 <input type="checkbox"/> 简体中文

Press UP/DOWN key to choose the language.

Reset parameters

RESET PARAMETERS	
Reset Type	= <input checked="" type="checkbox"/> Current <input type="checkbox"/> Relay1 <input type="checkbox"/> Relay2 <input type="checkbox"/> Relay3 <input type="checkbox"/> All

Press UP/DOWN key to choose the reset.

Notice: The reset will not affect the calibrated parameters.



Manual Konduktivitetsmätare DDG-2080x

Record query

Press UP key at the measurement mode to enter record query mode.

INPUT RECORD START NUMBER
0 1 0 3 0 0

Press UP/DOWN and SHIFT key to input record number then press ENTER key enter or press MODE key exit.

Display EC record at record

RECORD 020300		
15-08-14	0200	uS
21:20:49	025.0	°C
15-08-14	0201	uS
21:20:59	025.0	°C
15-08-14	0201	uS
21:21:09	025.0	°C
15-08-14	0201	uS
21:21:19	025.0	°C
15-08-14	0201	uS
21:21:29	025.0	°C

Display EC record at XY chart

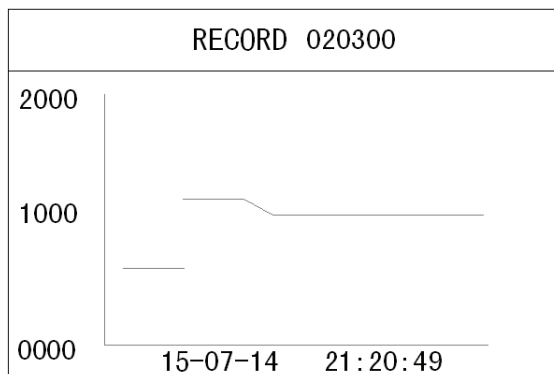

EC Calibration

Press MODE key to enter the password menu and then press UP/DOWN/SHIFT key to input password 1100 then press ENTER will enter to calibration mode or press MODE key to exit. If no key is be pressed and over 10 minutes then it will go back to measurement mode.

PASSWORD
0 0 0 0

PASSWORD
1 1 0 0



Manual Konduktivetsmätare DDG-2080x

www.processcenter.se

CALIBRATION
<ul style="list-style-type: none">■ Parameters Setting<input type="checkbox"/> Calibration<input type="checkbox"/> Reset Parameters

Press UP/DOWN key to select the functions and then press ENTER key to enter.

1. parameters setting: Input the parameters.
2. Calibration: Calibrate the EC.
3. Reset parameters: reset all of the calibrated parameters to default.

Notice:

If the cell constant is over than $\pm 30\%$, user should Replace the new electrode.

Parameters Setting

PARAMETERS SETTING
Temp. Coef. = 0 2.0 0 %
Ref. Temp. = 2 5.0 °C

1. Temperature Coefficient of solution: the range is form 0.01 to 40.00%
2. Reference Temperature: the range is from 15.0 to 35.0 °C

Calibration

CALIBRATION
Last Cell = 0 1.0 0 0 0
EC Reading = 1 0 4 3 μS
Temperature = + 0 2 5.0 °C
Input Cell = 0 1.2 0 0 0
Input Cell Constant

1. Put the electrode to the standard solution.
2. It will display the EC reading.
3. When the EC reading is stable then press UP/DOWN key to modify the cell constant to make the EC reading correspond to the standard solution.
4. If the EC Reading is over the EC range or the temperature is over 0.0-60.0°C then it will display error message on the button of LCD.

Reset parameters



Manual Konduktivitetmätare DDG-2080x

RESET PARAMETERS
RESET

This will reset all of the calibrated parameters to default.

Default

EC 20.00mA	corresponding	1000	uS	range: 100 - 2000
EC 4.00mA	corresponding	0	uS	range: 0 - 1900 difference : 100
RES 20.00mA	corresponding	10.00	MΩ	range: 1.00 - 20.00
RES 4.00mA	corresponding	0.00	MΩ	range: 0.00 - 19.00 difference : 1.00
SAL 20.00mA	corresponding	10.00	g/Kg	range: 1.00 - 78.00
SAL 4.00mA	corresponding	0.00	g/Kg	range: 0.00 - 77.00 difference : 1.00
TDS 20.00mA	corresponding	1000	ppm	range: 100 - 133000
TDS 4.00mA	corresponding	0	ppm	range: 0 - 132900 difference : 100
Temp. 20.00mA	corresponding	100.0	°C	range: 0.0 - 130
Temp. 4.00mA	corresponding	0.0	°C	range: -10.0 - 120.0 difference : 10.0
Current 1 output offset		0.00	mA	range: +/- 1.00
Current 2 output offset		0.00	mA	range: +/- 1.00
Current 1 filter		0	second	range: 0 - 120 second
Current 2 filter		0	second	range: 0 - 120 second
Current 1 fixed output		4.00	mA	range: 4.00 - 20.00
Current 2 fixed output		4.00	mA	range: 4.00 - 20.00
Current 1 HOLD type		last		range: fixed/last
Current 2 HOLD type		last		range: fixed/last
Relay 1 EC close S.P.		1000	uS	range: 0 - 2000
Relay 1 EC open S.P.		10	uS	range: 0 - 2000 difference : 1
Relay 1 RES close S.P.		10.00	MΩ	range: 0.00 - 20.00



Manual Konduktivitetsmätare DDG-2080x

www.processcenter.se

Relay 1 RES open S.P.	0.1	MΩ	range: 0.00 - 20.00 difference : 0.01
Relay 1 SAL close S.P.	10.00	g/Kg	range: 0.00 - 78.00
Relay 1 SAL open S.P.	0.1	g/Kg	range: 0.00 - 78.00 difference : 0.01
Relay 1 TDS close S.P.	1000	ppm	range: 0 - 133000
Relay 1 TDS open S.P.	10	ppm	range: 0 - 133000 difference : 1
Relay 1 delay time	0	second	range: 0 - 120
Relay 2 EC close S.P.	1000	uS	range: 0 - 2000
Relay 2 EC open S.P.	10	uS	range: 0 - 2000 difference :1
Relay 2 RES close S.P.	10.00	MΩ	range: 0.00 - 20.00
Relay 2 RES open S.P.	0.1	MΩ	range: 0.00 - 20.00 difference :0.01
Relay 2 SAL close S.P.	10.00	g/Kg	range: 0.00 - 78.00
Relay 2 SAL open S.P.	0.1	g/Kg	range: 0.00 - 78.00 difference :0.01
Relay 2 TDS close S.P.	1000	ppm	range: 0 - 133000
Relay 2 TDS open S.P.	10	ppm	range: 0 - 133000 difference :1
Relay 2 delay time	0	second	range: 0 - 120
Relay 3 period time	1.0	hour	range: 0 - 1000.0
Relay 3 clean time	10	second	range: 0 - 1000
Relay 3 delay time	0		range: 0 - 120
Relay 3 function	error alarm		range: clean/period alarm/ error alarm
Saving period	60	second	range: 5 - 120
ID address	1		range: 1 - 255
Baud rate	9600		range: 9600,19200,38400
EC Offset	0	uS	range: +/-100
Resistivity Offset	0.00	MΩ	range: +/-1.00
Salinity Offset	0.00	g/Kg	range: +/-1.00
TDS Offset	0	ppm	range: +/-100
Mode	EC		range: EC,RES,SAL,TDS
Measuring range	0-2000uS		range: 0-20.00uS/0-200.0uS 0-2000uS/0-20.00mS 0-200.0mS/0-2000mS
Temp. Offset	0.0	°C	range: +/- 5.0
Manual Temp. for measurement	25.0	°C	range: -10.0 - 130.0
Manual Temp. for calibration	25.0	°C	range: 0.0 - 60.0



Manual Konduktivitetmätare DDG-2080x

www.processcenter.se

Language	English	range: English/traditional Chinese/simple Chinese
Filter	1	range: 0 - 10
Temp. compensation	ATC	range: ATC/MTC
Temp. probe	NTC30K	range: Pt1000, NTC30K
Record type	record	range: record/XY chart

Password

Press MODE key

1100:Calibration mode

1200:Setting mode

If no key is be pressed and over 10 minutes then it will go back to measurement mode.

Error code

Error 01	memory error
Error 02	reading is over maximum
Error 03	reading is under minimum
Error 04	temperature is over maximum
Error 05	temperature is under minimum
Error 06	current 1 output is over 20.5 mA,the maximum is 22.00mA
Error 07	current 1 output is under 3.8 mA, the minimum is 3.5mA
Error 08	current 2 output is over 20.5 mA,the maximum is 22.00mA
Error 09	current 2 output is under 3.8 mA, the minimum is 3.5mA
Error 10	record error
Error 11	ADC damage
Error 99	default parameters lost

RS485 command

The instrument use the standard Mod bus-RTU protocol, all of the data are word type(2 bytes), the range is -32767~32767 ,16 system.

PC command:

	ID address	command	Start address	Data number	CRC16
length	1 byte	1byte	2 byte	2 byte	2 byte
Ex.	0x01	0x03	0x0001	0x0001	0xD5CA



Manual Konduktivitetsmätare DDG-2080x

www.processcenter.se

Instrument response:

	ID address	command	Data number	data	CRC16
length	1 byte	1 byte	1byte	N byte	2 byte
Ex.	0x01	0x03	0x02	0x02 0xBC	0xB895

If response is 01, the command is wrong.

If response is 02, the address is not correct.

If response is 03, data number is not correct.

command 03: read the settings

command 04: read the readings

04:definition

address

(00)	0x00	EC/RES/SAL/TDS reading1	reading: floating unit is uS
(01)	0x01	EC/RES/SAL/TDS reading2	reading:
		Reading 1 and reading 2 combine to a floating	
(02)	0x02	EC/RES/SAL/TDS current	reading:X 0.01
(03)	0x03	Temperature	reading:X 0.1
(04)	0x04	Temperature current	reading:X 0.01
(05)	0x05	Error code	reading:X 1
(06)	0x06		
(07)	0x07		
(08)	0x08		
(09)	0x09	Model type	fix to 3

03:definition

Address

(00)	0x00	EC 20.00mA corresponding	reading:X0.01/0.1/1
(01)	0x01	EC 4.00mA corresponding	reading:X0.01/0.1/1
(02)	0x02	RES 20.00mA corresponding	reading:X0.01
(03)	0x03	RES 4.00mA corresponding	reading:X0.01
(04)	0x04	SAL 20.00mA corresponding	reading:X0.01
(05)	0x05	SAL 4.00mA corresponding	reading:X0.01
(06)	0x06	TDS1 20.00mA corresponding	reading:X1
(07)	0x07	TDS2 20.00mA corresponding	reading:X1
(08)	0x08	TDS1 4.00mA corresponding	reading:X1
(09)	0x09	TDS2 4.00mA corresponding	reading:X1
(10)	0x0A	Temp. 20.00mA corresponding	reading:X 0.1
(11)	0x0B	Temp. 4.00mA corresponding	reading:X 0.1



Manual Konduktivitetsmätare DDG-2080x

www.processcenter.se

(12)	0x0C	Current 1 offset	reading:X0.01
(13)	0x0D	Current 2 offset	reading:X0.01
(14)	0x0E	Current 1 filter	reading:X1
(15)	0x0F	Current 2 filter	reading:X1
(16)	0x10	Current 1 fixed current	reading:X0.01
(17)	0x11	Current 2 fixed current	reading:X0.01
(18)	0x12	Current 1 HOLD type	reading:X1 0=fixed,1=last
(19)	0x13	Current 2 HOLD type	reading:X1 0=fixed,1=last
(20)	0x14	Relay 1 EC close S.P.	reading:X0.01/0.1/1
(21)	0x15	Relay 1 EC open S.P.	reading:X0.01/0.1/1
(22)	0x16	Relay 1 RES close S.P.	reading:X0.01
(23)	0x17	Relay 1 RES open S.P.	reading:X0.01
(24)	0x18	Relay 1 SAL close S.P.	reading:X0.01
(25)	0x19	Relay 1 SAL open S.P.	reading:X0.01
(26)	0x1A	Relay 1 TDS1 close S.P.	reading:X1
(27)	0x1B	Relay 1 TDS2 close S.P.	reading:X1
(28)	0x1C	Relay 1 TDS1 open S.P.	reading:X1
(29)	0x1D	Relay 1 TDS2 open S.P.	reading:X1
(30)	0x1E	Relay 1 delay time	reading:X1
(31)	0x1F	Relay 2 EC close S.P.	reading:X0.01/0.1/1
(32)	0x20	Relay 2 EC open S.P.	reading:X0.01/0.1/1
(33)	0x21	Relay 2 RES close S.P.	reading:X0.01
(34)	0x22	Relay 2 RES open S.P.	reading:X0.01
(35)	0x23	Relay 2 SAL close S.P.	reading:X0.01
(36)	0x24	Relay 2 SAL open S.P.	reading:X0.01
(37)	0x25	Relay 2 TDS1 close S.P.	reading:X1
(38)	0x26	Relay 2 TDS2 close S.P.	reading:X1
(39)	0x27	Relay 2 TDS1 open S.P.	reading:X1
(40)	0x28	Relay 2 TDS2 open S.P.	reading:X1
(41)	0x29	Relay 2 delay time	reading:X1
(42)	0x2A	Relay 3 clean period	reading:X0.1
(43)	0x2B	Relay 3 clean time	reading:X1
(44)	0x2C	Relay 3 delay time	reading:X1
(45)	0x2D	Relay 3 function	reading:X1 0:clean,1:period alarm ,2:Error alarm
(46)	0x2E	Record saving time	reading:X1
(47)	0x2F	EC Offset	reading:X0.01/0.1/1
(48)	0x30	Resistivity Offset	reading:X0.01
(49)	0x31	Salinity Offset	reading:X0.01
(50)	0x32	TDS Offset	reading:X1
(51)	0x33	Temp. offset	reading:X0.1



Manual Konduktivitetmätare DDG-2080x

www.processcenter.se

(52)	0x34	Language	reading:X1	0=English ,1=traditional Chinese,2=simple Chinese
(53)	0x35	Filter	reading:X1	
(54)	0x36	Temperature coefficient	reading:X0.01	0.01%-40.00%
(55)	0x37	Reference temperature	reading:X0.1	15.0-35.0°C
(56)	0x38	Mode	reading:	0=EC,1=RES,2=SAL,3=TDS
(57)	0x39	Temp. probe	reading:	0=Pt1000,1=NTC 30K