

Magnetisk Nivåvakt Typ Miniflottör Serie FC(D)

www.processcenter.se



Magnetisk Nivåvakt Typ Miniflottör Serie FC(D)

www.processcenter.se

PRODUCT INTRODUCTION

■ INTRODUCTION

The reed switch relies on two basic scientific principles namely: buoyancy and magnetism. Buoyancy causes the float (which contains a magnet) to rise with the liquid and magnetism helps open and close the switch. Since this product's this product has been introduced to the market, it has seen significant improvement and advances with regards to convenience, safety and lowering costs.

The float switches are extremely compact, simple and are easy to install on any small locations.

These switches are not affected by electrical interference and can withstand chemicals, high temperatures and pressures if the correct material of float switch is selected.

■ LIQUID PROPERTIES AND FLOATS

The switch's float should always have a specific gravity (SG) less than the liquid that holds the float.

(SG float < SG liquid)

When the liquid level rises the float will rise up due to its buoyancy. The float's upward movement will actuate the switch and close the circuit.

Different float materials can be used to ensure the float's SG level is less than the liquid. (Water's SG level is 1 while gasoline SG levels tend to be less than 1).

Because the float switches are activated by the magnetic field inside the float, make sure the liquid contains no iron traces or substances that can induce magnetic interference.

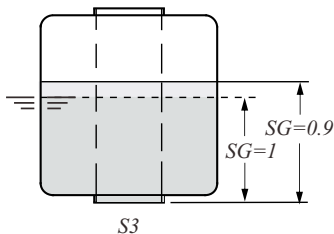

(Fig. 3)

■ WORKING PRINCIPLE

Fig. 1 illustrates the pivot activation (FCH Type reed switch). When float's magnet is moved close to the switch's stationary stem, the float magnet pushes the stem's switch circuit together and closes the electrical circuit. When the float magnet is moved away from the stem, the switch circuit separates and the circuit is opened.

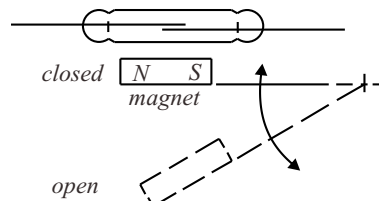

(Fig. 1)

Fig. 2 illustrates perpendicular activation (FC V TYPE float reed switches). When the liquid level rises and pushes the float up, the float's ring magnet (sealed in the float) moves close to the switch's stationary stem.

The magnet pushes the circuit together and when it makes contact, it closes the electrical circuit. When the float magnet moves away from the switch, the circuit contact is released and the switch is opened.

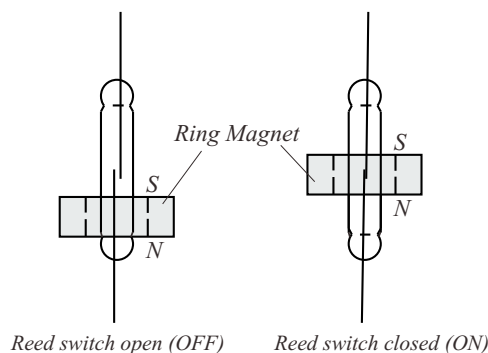

(Fig. 2)

Magnetisk Nivåvakt Typ Miniflottör Serie FC(D)

www.processcenter.se

CHEMICAL RESISTANCE

● Excellent ○ Good △ Fair × Corroded

Chemical	Concentration	Temp		Plastic				Rubber	Stainless	
		%	°C	°F	PVC	PP	PVDF	PTFE	NBR	304
Ammonia Water NH ₄ OH	10	40	104	●	●	●	●	○		
	10	80	176		○	●	●			
Aque Regia 3HCl+HNO ₃	10	40	104	△	△	●	●			
	10	80	176			●	●			
Benzene C ₆ H ₆	Pure	40	104	×	△	○	●			
		80	176			△	●			
Bleaching Liquor Ca(ClO) ₂	5	40	104	●		●	●			
	5	80	176			●	●			
	20	40	104	●		●	●			
	20	80	176			●	●			
Boric Acid H ₃ BO ₃	Satu	40	104	●	●	●	●	●		
		80	176		●	●	●	○		
Brine		40	104	●	●	●	●	●		
		80	176		●	●	●			
Butadiene CH ₂ =CH=CH=CH ₂	Gas	40	104	●		●	●			
		80	176			●	●			
Butane CH ₃ (CH ₂) ₂ CH ₃	Gas	40	104	●	●	●	●			
		80	176		●	●	●			
Nitric Acid HNO ₃	10	40	104	●	●	●	●	●	●	●
	10	80	176	×	○	●	●		●	
	30	40	104	●	●	●	●		●	●
	30	80	176	×	○	●	●		●	●
	50	40	104	○	○	●	●		●	●
	50	80	176	×	×	○	●			
	70	40	104	○	×	●	●		○	●
	70	80	176	×		○	●			
	98	40	104			○	○			
	98	80	176				△			
Oxalic Acid HOOCOOH	20	40	104	●	●	●	●	●		△
	20	80	176		●	●	●			
	50	40	104	●	●	●	●			△
	50	80	176		●	●	●			
Phosphoric Acid H ₃ PO ₄	10	40	104	●	●	●	●	●	●	●
	10	80	176		○	●	●	△	●	●
	50	40	104	●	●	●	●	●	●	●
	50	80	176		△	●	●	×	●	●
	80	40	104	●	●	●	●	○	●	●
80	80	176		△	●	●		●	●	
Sodium Hydroxide NaOH	15	40	104	●	●	●	●	●	●	●
	15	80	176		○	△	●	△	×	×
	30	40	104	●	●	●	●	●	●	●
	30	80	176		○	△	●	●	×	×
	50	40	104	●	●	○	●	●	●	●
50	80	176		○	×	●	●	×	×	
70	40	104	○	○	○	●				
70	80	176		○	×	●				

Chemical	Concentration	Temp		Plastic				Rubber	Stainless	
		%	°C	°F	PVC	PP	PVDF	PTFE	NBR	304
Sodium Hypochlorite NaClO	3	40	104	●	○	●	●		△	○
	3	80	176							
	5	40	104	●	○	●	●		△	○
	5	80	176							
	7	40	104	●	△	○	●		×	×
	7	80	176							
	10	40	104	●	△	●	●		×	×
	10	80	176							
	13	40	104	●	△	●	●		×	×
	13	80	176							
Sulfuric Acid H ₂ SO ₄	10	40	104	●	●	●	●	●	●	●
	10	80	176		●	●	●	○	○	○
	30	40	104	●	●	●	●	●	×	×
	30	80	176		●	●	●	○	×	×
	50	40	104	●	●	●	●	○	×	×
	50	80	176		●	●	●	△	×	×
	60	40	104	●	●	●	●	●	×	×
	60	80	176		○	●	●	○	×	×
	70	40	104	●	●	●	●	○	×	×
	70	80	176		○	●	●	△	×	×
80	40	104	●	●	●	●	●	×	×	
80	80	176		○	●	●	△			
90	40	104	○	●	●	●	△	×	×	
90	80	176		○	●	●	△			
98	40	104	△		●	○		○	○	
98	80	176			△	○				
Toluene C ₇ H ₈		40	104		△	△	●			
		80	176				○			
Chlorine Gas Cl ₂	Wet	40	104	○		●	●			
	Wet	80	176			△	●			
	Dry	40	104	●		●	●			
	Dry	80	176			●	●			
Chromic Acid H ₂ CrO ₄	10	40	104	●		●	●			
	10	80	176			●	●			
	20	40	104	△		●	●			
	20	80	176			●	●			
	40	40	104	△		●	●			
	40	80	176			●	●			
Hydrochloric Acid HCl	15	40	104	●	●	●	●	○		
	15	80	176		●	●	●			
	25	40	104	●	●	●	●	×		
	25	80	176		●	●	●			
	35	40	104	●	●	●	●	×		
	35	80	176		○	●	●			
	38	40	104	●	●	●	●	×		
	38	80	176		○	●	○			

Magnetisk Nivåvakt Typ Miniflottör Serie FC(D)

www.processcenter.se

● Excellent ○ Good △ Fair × Corroded

Chemical	Concentration %	Temp		Plastic				Rubber		Stainless	
		°C	°F	PVC	PP	PVDF	PTFE	NBR	304	316	
Citric Acid	10	40	104	●	●	●	●	●	●	●	
$C_6H_8O_7$	10	80	176	○	●	●	●	●			
Gasoline	10	40	104	●		●	●				
		80	176			●	●				
Diesel Fuels		40	104			●	●		●	●	
		80	176			●	●		●	●	
Ethyl Alcohol C_2H_5OH	Pure	40	104	●	●	●	●	●	○	○	
		80	176		○	●	●	○			
Formic Acid $HCOOH$	90	40	104	○	○	●	●				
		80	176			●	●				
Hydrofluoric Acid HF	Dilute	40	104	●	○	●	●				
		80	176		○	●	●				
	30	40	104	○	○	●	●				
		80	176	×	○	●	●				
	40	40	104	△	○	●	●				
		80	176		○	●	●				
	50	40	104	△	○	●	●				
		80	176		○	●	●				
Hydrogen peroxide H_2O_2	5	40	104	●	●	●	●		○	●	
		80	176		○	●	●				
	20	40	104	●	●	●	●				
		80	176		○	●	●				
	30	40	104	○	○	●	●				
		80	176		△	●	●				
	50	40	104	△	×	●	●				
		80	176			●	●				
	90	40	104			●	●				
		80	176			●	●				
Isopropyl Alcohol $(CH_3)_2CHOH$	Pure	40	104	●	●	●	●	○			
		80	176			●	●				
Kerosene		40	104	●	○	●	●				
		80	176			●	●				
Methyl Alcohol CH_3OH		40	104	○	●	●	●	△			
		80	176		○	●	●				
Methyl Ethyl Ketone $CH_3COC_2H_5$		40	104		△		●				
		80	176				●				
Potassium Chromate K_2CrO_4		40	104	●	●	●	●	●			
		80	176		○	●	●	○			

Magnetisk Nivåvakt Typ Miniflottör Serie FC(D)

www.processcenter.se

REED SWITCH PROTECTION

■ INDUCTIVE LOADS

When using reed switches for inductive loads such as motors, relay coil, solenoids, etc., the contact points will sometimes be subjected to high voltages. Such high induced voltages may damage the reed switch or significantly reduce its life.

Therefore, circuit protectors such as: RC snubbers, varistors or clamping diodes are recommended. (see Fig. 4a, Fig. 4b, Fig. 4c)

- Do not directly connect the solenoid valve, motor or magnetic switch.

$$C = \frac{I^2}{10} \text{ (uF)}$$

$$R = \frac{E}{10I(1 + \frac{E}{50})}$$

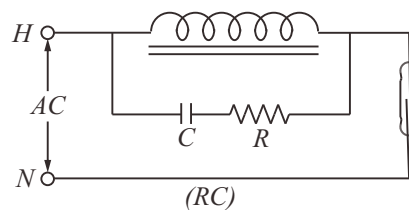

Fig. 4 (a)

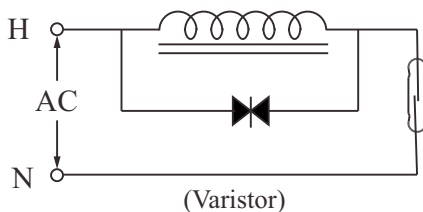

Fig. 4 (b)

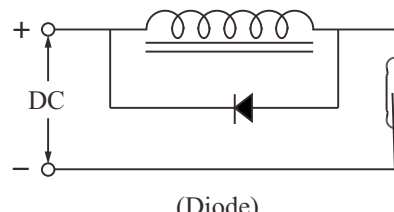

Fig. 4 (c)

■ CAPACITIVE LOADS

When using reed switches for capacitive loads such as capacitors, incandescent lamps or long cables, the contact points will be subjected to electrical surges. Therefore, protective circuits such as: surge suppressors or current limiting resistors are recommended. (Fig. 5a, Fig. 5b)

Therefore, circuit protectors such as: RC snubbers, varistors or clamping diodes are recommended (Fig. 5a, Fig. 5b)

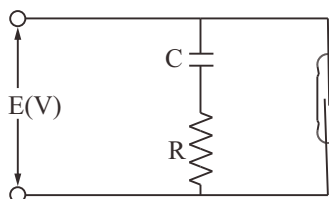

Fig. 5 (a)

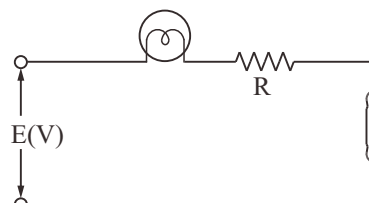
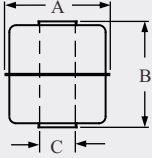
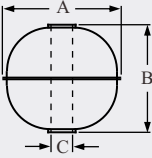
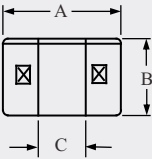
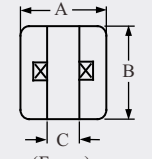
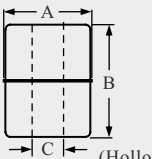

Fig. 5 (b)

Magnetisk Nivåvakt Typ Miniflottör Serie FC(D)

www.processcenter.se

FLOAT SPECIFICATIONS

MODEL	TYPE	$\phi A \times B \times \phi C$	S.G.	Max. Pressure (kg/cm ²)	Weight (g)	Material/Color	Max. Temp. (°C)
	S1	28x28x9.5	E>0.7	10	8	SUS 304 / 316L	200
	S3	45x55x15	E>0.65	12	37.6	SUS 316	200
	S6	75x108x20	E>0.5	10	165	SUS 304	200
	S13	38x50x15	E>0.62	12	22.9	SUS 316L	200
	S2	41x38x11	E>0.7	35	19.5	SUS 316	200
	S4	52x52x15	E>0.55	30	33.4	SUS 316	200
	S5	75x73x20	E>0.7	30	102.4	SUS 316	200
	S7	30x28x9.5	E>0.82	25	8	SUS 304 / 316L	200
	S8	100x100x20	E>0.5	15	249.7	SUS 304	200
	S9	150x150x30	E>0.45	15	534	SUS 304	200
	S11	28x32x9.5	E>0.82	30	8.1	SUS 316	200
 <p>(Hollow)</p>	P1	25x15x10	E>0.65	4	3.5	PP / white black	80
	P2	25x25x10	E>0.55	4	5	PP / white black	80
	P3	48x45x18.5	E>0.6	5	35.5	PP / black	80
	P4	20x25x10	E>0.7	4	3.7	PP / white black	80
	P5	20x20x8.1	E>0.75	4	4	PP / white	80
	P8	18.2x15.3x7.2	E>0.8	4	1.82	PP / black	80
	 <p>(Foam)</p>	Q6	20x20x7.5	E>0.75	ATM	3.5	PP / white
Q7		25x25x8.8	E>0.7	ATM	6.7	PP / white	80
N1		25x15x10	E>0.5	ATM	2.7	NBR / black	100
N2		18.5x26x10	E>0.7	ATM	3.3	NBR / black	100
N3		19x20x10	E>0.55	ATM	2.4	NBR / black	100
N4		17.5x25x10	E>0.65	ATM	2.5	NBR / black	100
N5		30x45x12.8	E>0.5	ATM	11.5	NBR / black	100
 <p>(Hollow)</p>	F2	42x44x14	E>0.63	5	18.5	PP	80
	F3	45x45x20	E>0.65	5	35.7	PP	80
	F4	48x62x18	E>0.85	5	65.3	PVDF	120

Magnetisk Nivåvakt Typ Miniflottör Serie FC(D)

www.processcenter.se

STAINLESS STEEL SWITCHES

► FD MH50/ 56

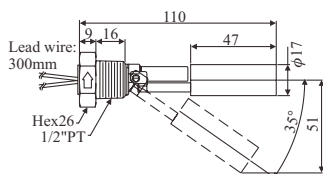

► FD MH50A /56A

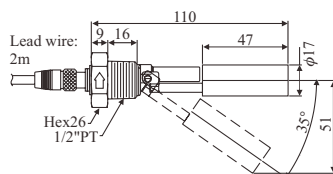

► FD MH50C /56C

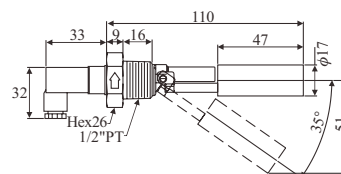

► FD MH60/ 66

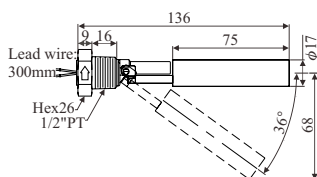

► FD MH60A/ 66A

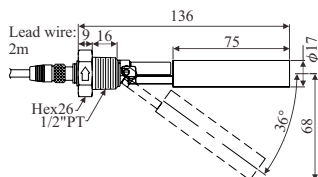

► FD MH60C/ 66C

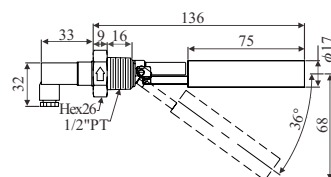

■ SPECIFICATIONS

Type	Material	Switching Capacity Max.	Switching Voltage Max.	Switching Current Max.	Carry Current Max.	Lead Wire	Max. Pressure	Operating Temp.	Suitable Sp. Gr.
FDMH50/56 FDMH60/66	SUS 304 SUS 316L	50W/SPST	240Vac 200Vdc	0.5A	1A	XLPE or TEFLON	5 kg/cm ²	-20~120°C (Max.200°C)	FDMH5:0.92 FDMH6:0.75
FDMH50A/56A FDMH60A/66A	SUS 304 SUS 316L	50W/SPST	240Vac 200Vdc	0.5A	1A	XLPE or TEFLON	5 kg/cm ²	80°C	FDMH5:0.92 FDMH6:0.75
FDMH50C/56C FDMH60C/66C	SUS 304 SUS 316L	50W/SPST	240Vac 200Vdc	0.5A	1A	XLPE or TEFLON	5 kg/cm ²	-20~120°C	FDMH5:0.92 FDMH6:0.75



Magnetisk Nivåvakt Typ Miniflottör Serie FC(D)

www.processcenter.se

HOW TO ORDER SINGLE SWITCHES

FDMH **5** **0** **A** **B** **R** (**0** **5** **F**)

Type _____

5: ϕ 17x47L (SG: 0.92) 6: ϕ 17x75L (SG: 0.75)

Material _____

0: SUS304 6: SUS316L

Connection _____

– : without A: M12 C: DIN

※ Connector M12 whose standard wire length is 2M

※ Connector M12 whose wire is durable with oil and made of PVC / PUR, Max.Temp: 80°C

Connecting Type _____

BR:1/2"PF BQ: 1/2"PT BU: 1/2"NPT BT: 1/2"BSP

Lead wire Length (Unit=100mm) _____

05: 500mm (below 500mm) ※ 500mm per Unit

10: 1000mm (501~1000mm) ※ 300mm (Standard length)

15: 1500mm (1001~1500mm)

⋮

Material of Lead wire _____

F: SILICON (150°C) AWG24 X ϕ 4

T: TEFLON (200°C) AWG24

X: XLPE (125°C) AWG22 (Standard)

※ Material of Wetted parts "SUS304" ◦

Magnetisk Nivåvakt Typ Miniflottör Serie FC(D)

www.processcenter.se

MARINE LEVEL SWITCHES

► FDMRN5A0B

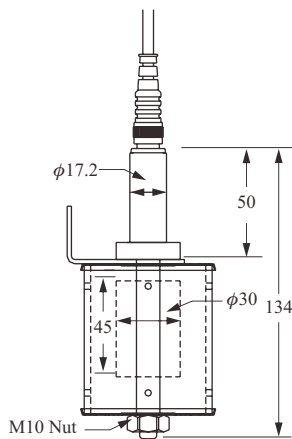

► FDMRN5B0B

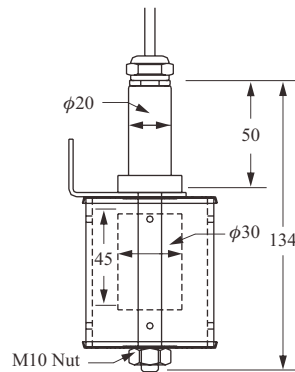

► FDMRN5C0B

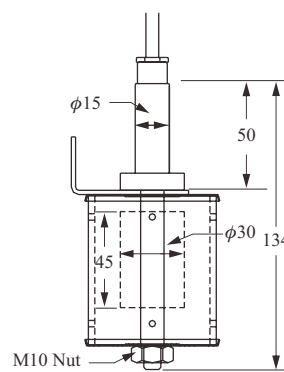

► FDMRN5D0B

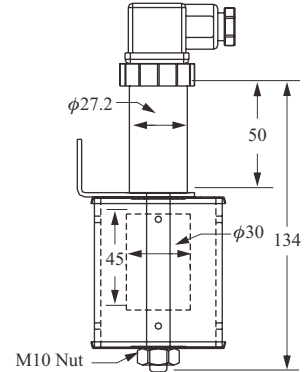

■ SPECIFICATIONS

Type	Material	Switching Capacity Max.	Switching Voltage Max.	Switching Current Max.	Carry Current Max.	Lead Wire	Max. Pressure	Operating Temp.	Suitable Sp. Gr.
FDMRN5A0B	SUS 304 (Float:NBR)	50W/SPST	240Vac 200Vdc	0.5A	1A	M12, 2 meter	ATM	Max. 80°C	0.5
FDMRN5B0B	SUS 304 (Float:NBR)	50W/SPST	240Vac 200Vdc	0.5A	1A	PVC,22 AWG	ATM	Max. 80°C	0.5
FDMRN5C0B	SUS 304 (Float:NBR)	50W/SPST	240Vac 200Vdc	0.5A	1A	Silicon	ATM	Max. 100°C	0.5
FDMRN5D0B	SUS 304 (Float:NBR)	50W/SPST	240Vac 200Vdc	0.5A	1A	DIN 43650	ATM	Max. 80°C	0.5

Magnetisk Nivåvakt Typ Miniflottör Serie FC(D)

www.processcenter.se

MARINE LEVEL SWITCHES

► FDMRN8A0B

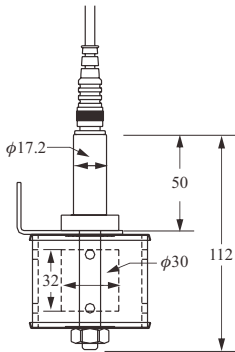

► FDMRN8B0B

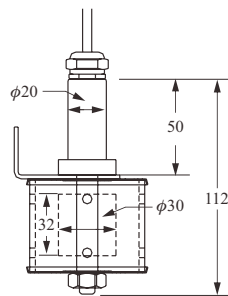

► FDMRN8C0B

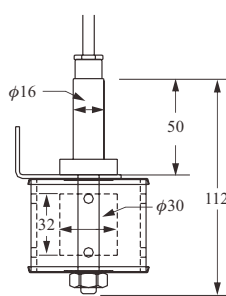

► FDMRN8D0B

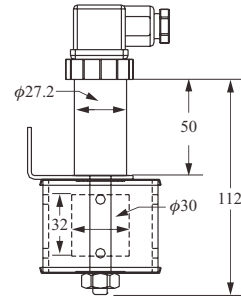

■ SPECIFICATIONS

Type	Material	Switching Capacity Max.	Switching Voltage Max.	Switching Current Max.	Carry Current Max.	Lead Wire	Max. Pressure	Operating Temp.	Suitable Sp. Gr.
FDMRN8A0B	SUS 304 (Float:NBR)	50W/SPST	240Vac 200Vdc	0.5A	1A	M12, 2 meter	ATM	Max. 80°C	0.7
FDMRN8B0B	SUS 304 (Float:NBR)	50W/SPST	240Vac 200Vdc	0.5A	1A	PVC, 22 AWG	ATM	Max. 80°C	0.7
FDMRN8C0B	SUS 304 (Float:NBR)	50W/SPST	240Vac 200Vdc	0.5A	1A	Silicon	ATM	Max. 100°C	0.7
FDMRN8D0B	SUS 304 (Float:NBR)	50W/SPST	240Vac 200Vdc	0.5A	1A	DIN 43650	ATM	Max. 80°C	0.7

■ FDB-0450 PARTS OF SLOSH SHIELD

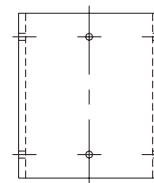
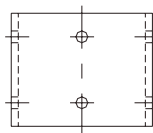
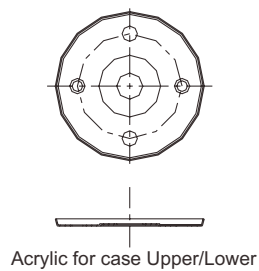
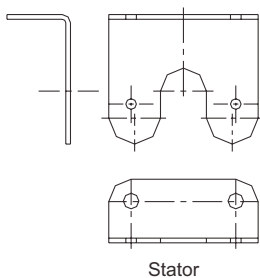

Magnetisk Nivåvakt Typ Miniflottör Serie FC(D)

www.processcenter.se

HOW TO ORDER MARINE LEVEL SWITCHES

FDMR **N5** **A** **0** **B** (**05**)

Float Type

N5: ϕ 30x45L (NBR) N8: ϕ 30x32L (NBR)

Connection Type

A: M12 B,C: Cable D: DIN Connection

- ※ Connector M12 whose standard wire length is 2M
- ※ Connector M12 whose wire is endurable with oil and made of PVC / PUR, Max.Temp: 80°C

Tube Material

0: SUS304, 6: SUS316L

Contact Form

A: Normal open(N.O.) B: Normally closed(N.C.)

Lead wire Length (L)

- 05: 500mm (01~500mm) ※ 500mm per Unit
- 10: 1m (501mm~1m) ※ 300mm (Standard length)
- 15: 1.5m (1.01~1.5) ※ 2M is standard length of lead wire for ASI connection

⋮

FDMRN5□A0

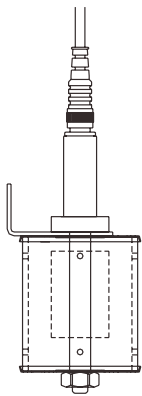

A TYPE

FDMRN5□B0

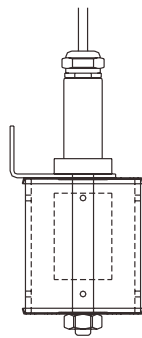

B TYPE

FDMRN5□C0

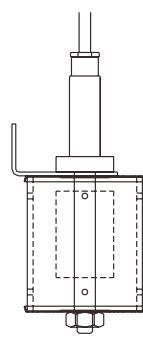

C TYPE

FDMRN5□D0

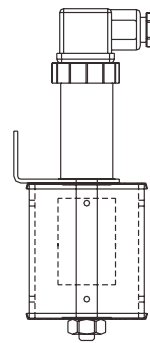

D TYPE

FDMRN8□C0

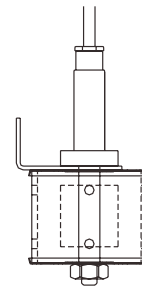

C TYPE

Magnetisk Nivåvakt Typ Miniflottör Serie FC(D)

www.processcenter.se

STAINLESS STEEL MODELS

► FD 30□1/ FD 35□1

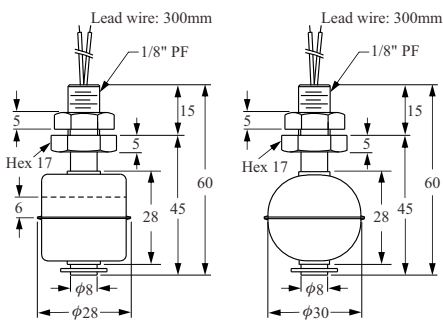

Washer: NBR
Drill hole $\phi 10$ mm

► FD 40□1

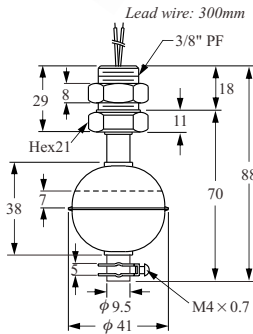

Washer: NBR
Drill hole $\phi 17$ mm

► FD 45□1

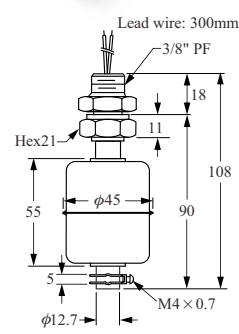

Washer: NBR
Drill hole $\phi 17$ mm

► FD 30□2

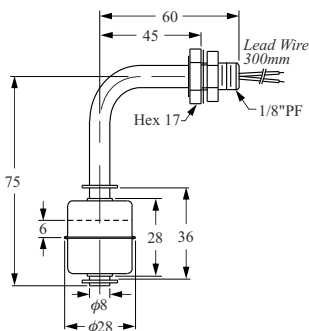

Washer: NBR
Drill hole $\phi 10$ mm

► FD 40□2

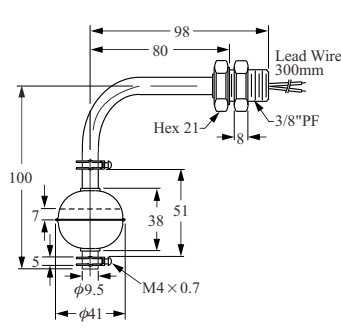

Washer: NBR
Drill hole $\phi 17$ mm

► FD 45□2

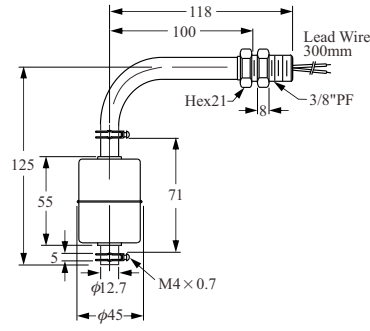

Washer: NBR
Drill hole $\phi 17$ mm

Magnetisk Nivåvakt Typ Miniflottör Serie FC(D)

www.processcenter.se

METAL TYPES

► FD 50□1

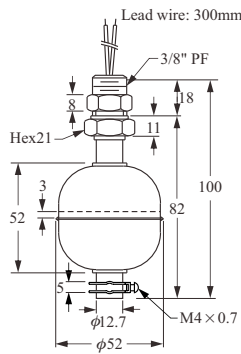

Washer: NBR
Drill hole ϕ 17mm



► FD 50□2

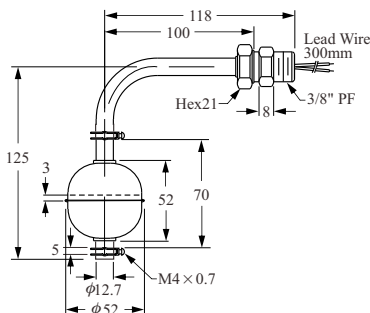

Washer: NBR
Drill hole ϕ 17mm



► FD 75□1

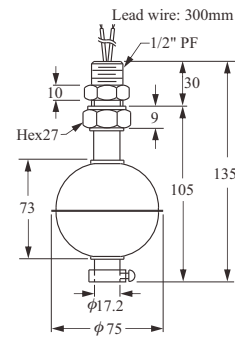

Washer: NBR
Drill hole ϕ 21mm



■ SPECIFICATIONS

Type	FD30□1D FD30□2D	FD40□1D FD40□2D	FD45□1D FD45□2D	FD50□1D FD50□2D	FD75□1G	FD10□1G
Description						
Switching Capacity Max.	50W SPST	50W SPST	50W SPST	50W SPST	60W SPDT	
Switching Voltage Max.	240Vac/200Vdc				220Vac	
Switching Current Max. (A)	0.5A	0.5A	0.5A	0.5A	1A	
Carry Current Max. (A)	1A	1A	1A	1A	2A	
Lead Wire	XLPE (UL3266, AWG22)					
Reversible Switch Action	YES / below 80°C, NO / UP 80°C				NO	NO
Max. Pressure (Kg/cm²)	10	30	12	30	30	10
Operating Temperature	-20~120°C (OPTION 200°C)					
Material	Stainless Steel SUS304, 316					
Suitable Specific Gravity	0.7	0.7	0.65	0.55	0.55	0.5



Magnetisk Nivåvakt Typ Miniflottör Serie FC(D)

www.processcenter.se

ORDERING METAL SWITCHES

FD **30** **6** **2** **D** **A** (**10** **H**)

Order No./ Model

- 10 Float : ϕ 75x108, Screw : 1/2"PF
- 30 Float : ϕ 28x28, Screw : 1/8"PF
- 31 Float : ϕ 28x28, Screw : 1/8"NPT
- 35 Float : ϕ 30x28, Screw : 1/8"PF
- 36 Float : ϕ 30x28, Screw : 1/8"NPT
- 40 Float : ϕ 41x38, Screw : 3/8"PF
- 45 Float : ϕ 45x55, Screw : 3/8"PF
- 50 Float : ϕ 52x52, Screw : 3/8"PF
- 75 Float : ϕ 75x70, Screw : 1/2"PF

Material of Wetted parts

- 0 : SUS304
- 6 : SUS316

Mounting

- 1 : Top or Bottom Mounting
- 2 : Side Mounting

Switching Capacity Max.

- D: 50W 240Vac /200Vdc SPST 
- F: 10W 125Vac SPST
- G: 60W 220Vac SPDT (only use for tube ϕ 17.2)
- S: Others

Contact Mode

- A: Normally Open (N.O.) SPST ※ High Temperature only available for A or B Type
- B: Normally Closed (N.C.) SPST
- C: 1C SPDT
- D: N.C. Reversible
- E: N.O. Reversible

Lead wire Length (Unit=100mm)

- 05: 500mm (below 500mm) ※ 500mm per Unit
- 10: 1000mm (501~1000mm) ※ 300mm (Standard length)
- 15: 1500mm (1001~1500mm)

⋮

Material of Lead wire

- B: PVC cable (80°C) ---- AWG24
- C: PVC cable (80°C) ---- AWG22 X ϕ 4 ※ ϕ 8 Stem is not suitable.
- D: XLPVC (105°C) ---- AWG22
- F: SILICON cable (150°C) ---- AWG24 X ϕ 4
- P: PVC (80°C) ---- AWG22
- T: TEFLON (200°C) ---- AWG24
- X: XLPE (125°C) ---- AWG22 (Standard)

High Temp. (200°C)

Magnetisk Nivåvakt Typ Miniflottör Serie FC(D)

www.processcenter.se

PLASTIC OH MODELS

► FCH11QD

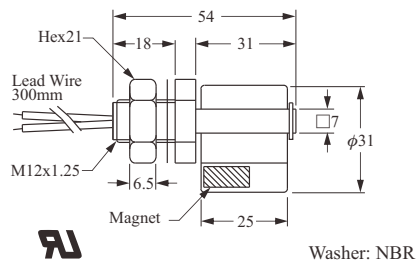

■ Installation / N.C./ N.O. Action Position

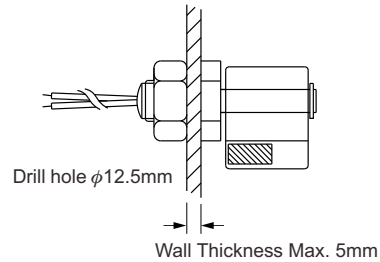

Normally open
N.O.

Normally closed
N.C.

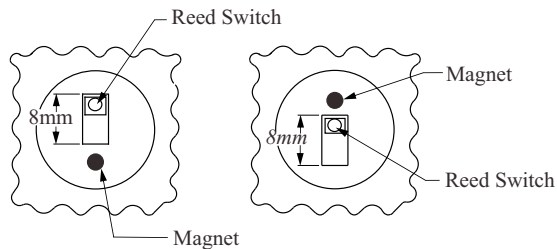

- All the products in this range come with UL E161587 approval.
- All the products in this range are designed to be side mounted.
- Water's specific gravity is used as the reference point for calculations.

■ SPECIFICATIONS

Description	Type	FCH11QD	FCH21PD FCH31PD	FCH23FD FCH33FD	FCH24YD FCH34YD	FCH25GD FCH35GD
Switching Capacity Max.		50W SPST				
Switching Voltage Max.		240VAC / 200Vdc				
Switching Current Max. (A)		0.5A				
Carry Current Max. (A)		1A				
Lead Wire		PVC AWG22	XLPE AWG22			
Max. Pressure (Kg/cm ²)		ATM	4 kg/cm ²	2 kg/cm ²		
Operating Temperature		-20~80°C		-20~120°C		
Material		PP		PVDF	Nylon	Polysuphone
Suitable Specific Gravity		0.6	0.65	0.85	0.8	0.85
Weight		25 g	H21: 22 g H31: 21 g	25 g	23 g	25.4 g

Magnetisk Nivåvakt Typ Miniflottör Serie FC(D)

www.processcenter.se

PLASTIC OH MODELS

► FC H21PD / H31PD



- FCH2 and FCH3 models are available in PP, Nylon, and PVDF.
- Special lead wire/cable are available on request.
- Different reed switches are available for selection.
- For standard design specifications see catalog (p14).
- OEM designs are welcome.

■ Optional FC H21PDO(Round)

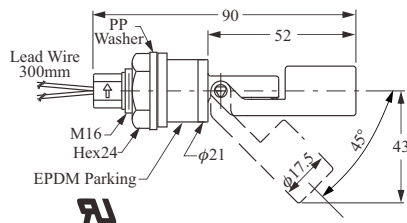

■ Installation / N.C. / N.O. Action Position

[External mounting]

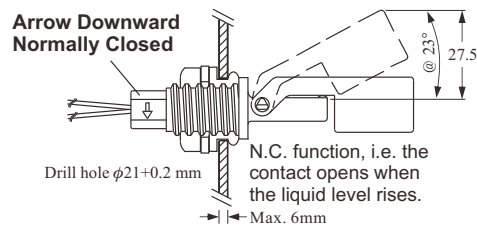

■ Standard FC H21PDD (Hexagon)

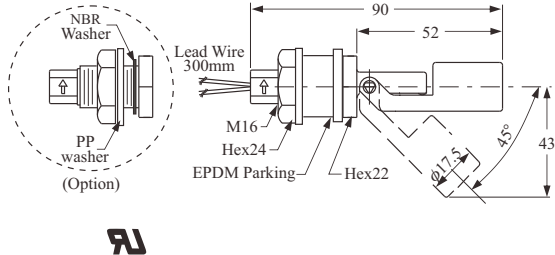

[Internal mounting]

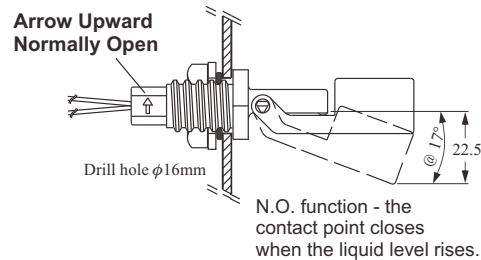

■ FC H31PD

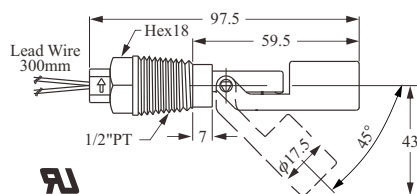

[External mounting]

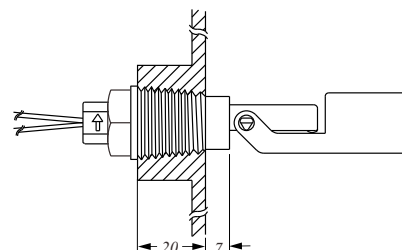

Magnetisk Nivåvakt Typ Miniflottör Serie FC(D)

www.processcenter.se

PLASTIC OH MODELS

► FC H41PD / H51PD



■ Installation / N.C. / N.O. Action Position

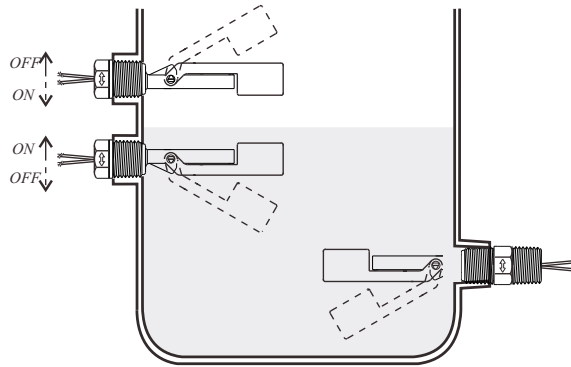

■ FC H41PD

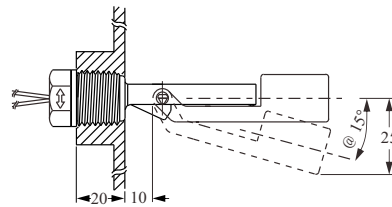
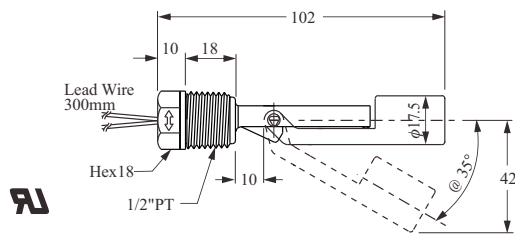

N.O. function, i.e. the contact closes when the liquid level rises.

■ FC H51PD

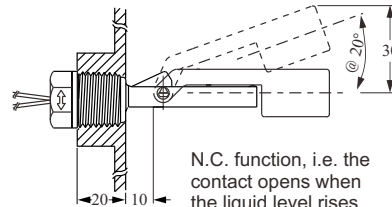
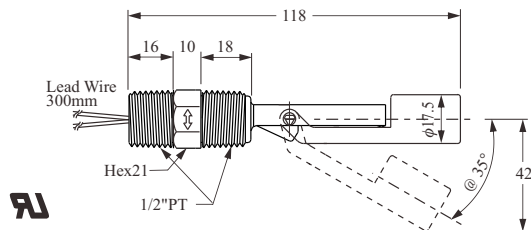

N.C. function, i.e. the contact opens when the liquid level rises.

■ FC H61PD

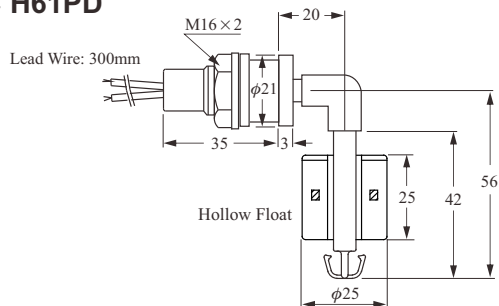

■ SPECIFICATIONS

Type	Material	Switching Capacity Max.	Switching Voltage Max.	Switching Current Max.	Carry Current Max.	Lead Wire	Max. Pressure	Operating Temp.	Suitable Sp. Gr.	Weight
FCH41PD	PP	50W/SPST	240Vac 200Vdc	0.5A	1A	XLPE	4 kg/cm ²	-20~80°C	0.55	20g
FCH51PD						PVC				25g
FCH61PD						31g				

Magnetisk Nivåvakt Typ Miniflottör Serie FC(D)

www.processcenter.se

PLASTIC OV MODELS

► FC V11QF

► FC V21QD

► FC V31PD

► FC V33FD, 34YD, 35GD

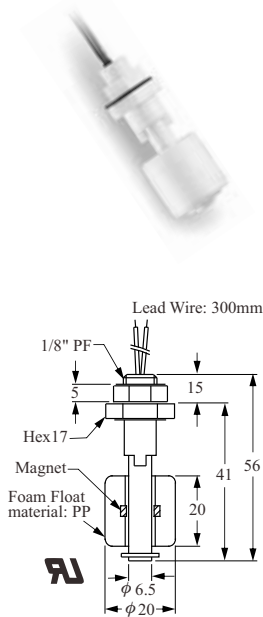

Washer: NBR
Drill hole ϕ 10mm

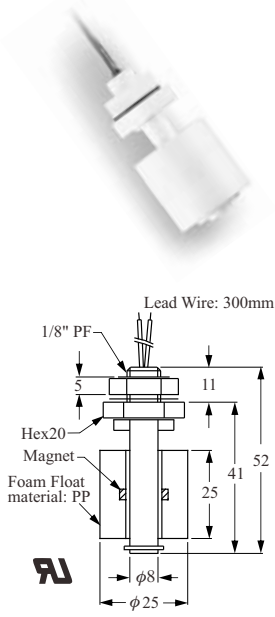

Washer: NBR
Drill hole ϕ 10mm

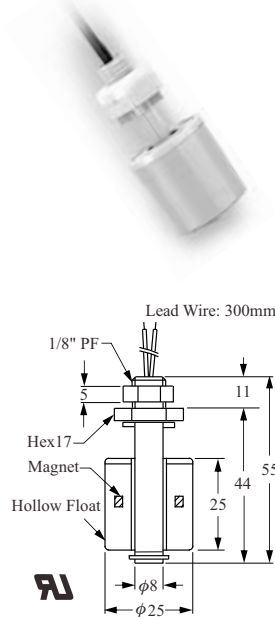

O-ring: VITON
Drill hole ϕ 10mm

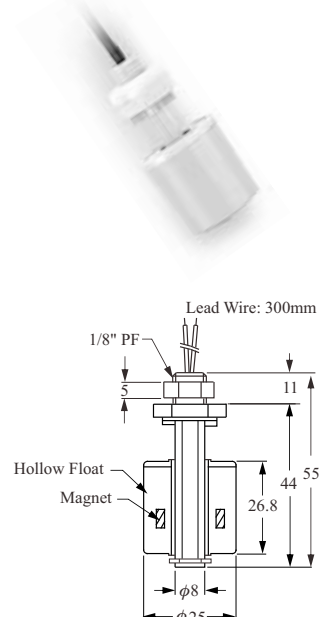

O-ring: VITON
Drill hole ϕ 10mm

■ SPECIFICATIONS

Description \ Type	FC V11QF	FC V21QD	FC V31PD	FC V33FD	FC V34YD	FC V35GD
Switching Capacity Max.	10W SPST	50W SPST	50W SPST			
Switching Voltage Max.	125Vac	240Vac / 200Vdc	240Vac / 200Vdc			
Switching Current Max. (A)	0.5A		0.5A			
Carry Current Max. (A)	1A		1A			
Lead Wire	UL 1007 AWG22 PVC		UL 1007 AWG22 PVC	XLPE AWG22		
Reversible Switch Action	YES/ 80°C down					
Max. Pressure (Kg/cm ²)	ATM		4 kg/cm ²	2 kg/cm ²		
Operating Temperature	-20~80°C		-20~80°C	-20~120°C		
Material	PP		PP	PVDF	Nylon	Polysuphone
Suitable Specific Gravity	0.75	0.7	0.55	0.85	0.8	0.75
Weight (g)	12 g	18 g	12.8 g	18 g	15 g	18 g

Magnetisk Nivåvakt Typ Miniflottör Serie FC(D)

www.processcenter.se

PLASTIC OV MODELS

► FC V11NF

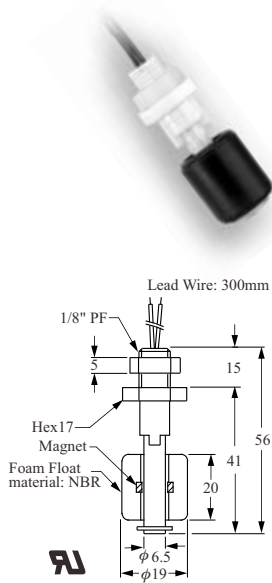

Washer: NBR
Drill hole ϕ 10mm

► FC V81PD

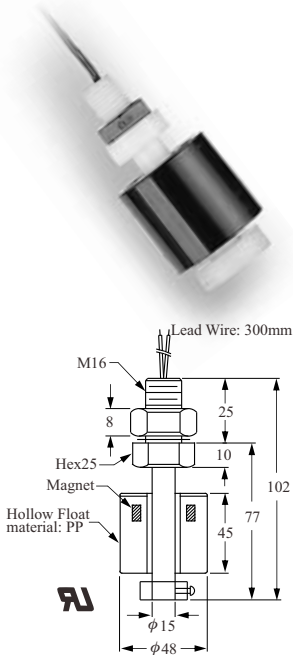

Washer: NBR
Drill hole ϕ 16mm

► FC V41PD, V41QD

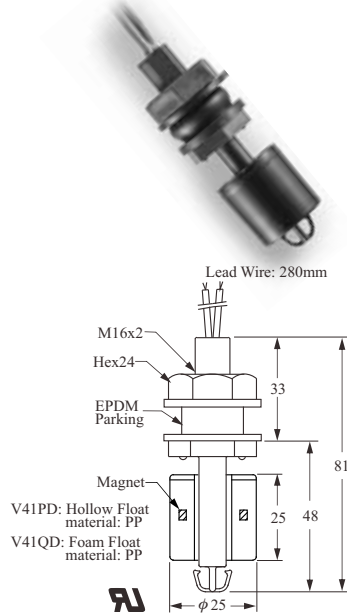

V41PD: Hollow Float material: PP
V41QD: Foam Float material: PP

Washer: NBR
Drill hole ϕ 16mm

► FC V41ND

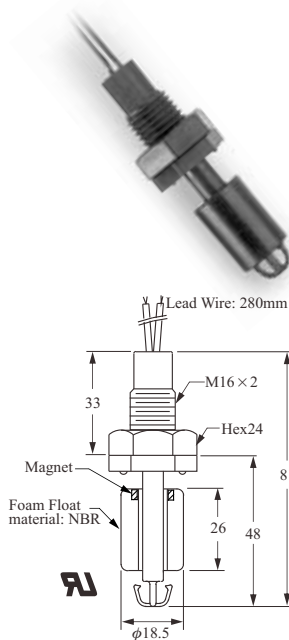

Washer: NBR
Drill hole ϕ 16mm

► FC V61PF, V61NF

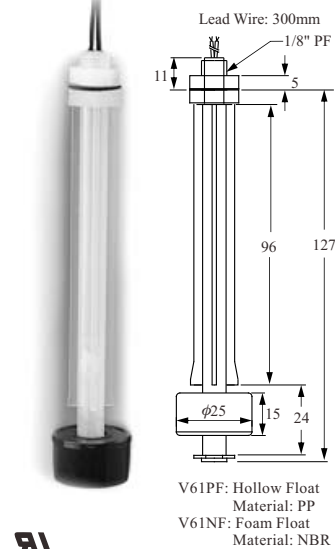

V61PF: Hollow Float material: PP
V61NF: Foam Float material: NBR

Washer: NBR
Drill hole ϕ 10mm

► FC V51PD

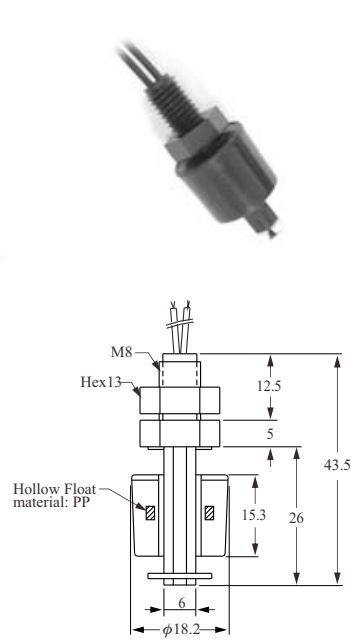

O-Ring: VITON
Drill hole ϕ 8.5mm

Magnetisk Nivåvakt Typ Miniflottör Serie FC(D)

www.processcenter.se

PLASTIC OV MODELS

■ SPECIFICATIONS

Type	FC V11NF	FC V61PF FC V61NF	FC V41PD FC V41QD	FC V81PD	FC V41ND	FC V51PD
Description						
Switching Capacity Max.	10W SPST		50W SPST			
Switching Voltage Max.	125Vac (Break Down 250Vac)		240Vac / 200Vdc			
Switching Current Max. (A)	0.5A					
Carry Current Max. (A)	1A —					
Lead Wire	XLPE AWG22	UL 1007 AWG22 PVC				
Reversible Switch Action	NO	NO	YES	NO	NO	NO
Max. Pressure (kg/cm ²)	ATM	V61P: 4kg/cm ² V61N: ATM	V41P: 4kg/cm ² V41Q: ATM	4 kg/cm ²	ATM	4 kg/cm ²
Operating Temperature	-20~80°C					80°C
Material	PP (except V11N, V61N, V41N: NBR float)					
Suitable Specific Gravity	0.55	0.65 0.5	0.55 0.7	0.6	0.7	0.8
Weight (g)	11 g	16 g	23 g	180 g	17 g	8.2 g

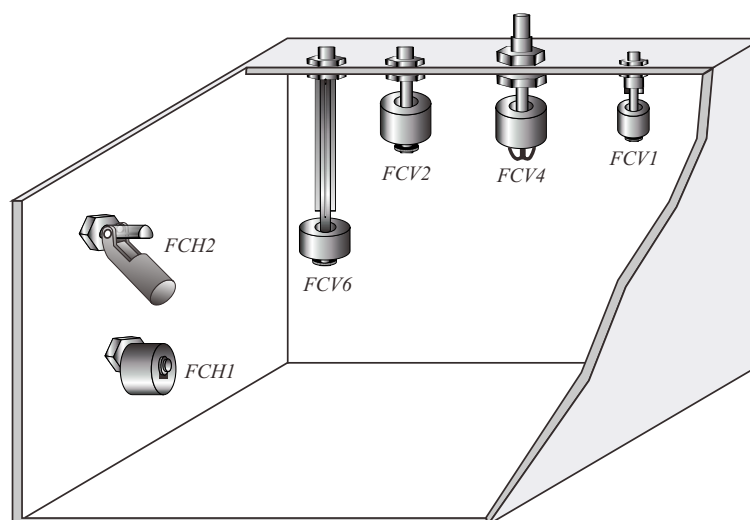

Magnetisk Nivåvakt Typ Miniflottör Serie FC(D)

www.processcenter.se

CUSTOMIZED PLASTIC MODELS

► FC PV1

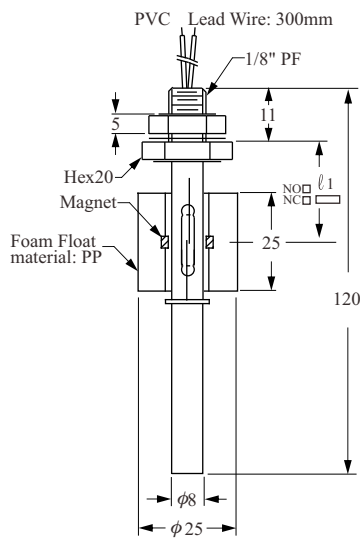

O-Ring: VITON

► FC PV2

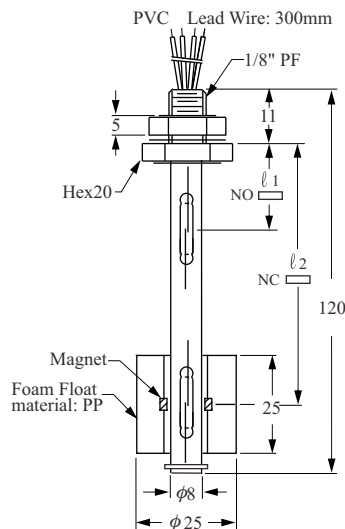

O-Ring: VITON

► FC PV3

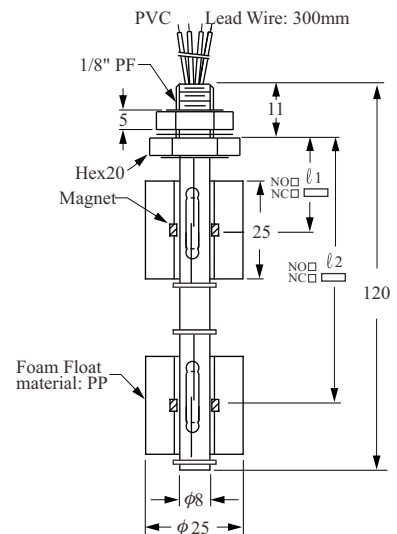

O-Ring: VITON

- NOTE: Float material's are optional.

The above items are custom-built when client demands are unique. The benefits are listed below:

- FCPV1 One float for one level activation.
- FCPV2 One float with 2 reed switches.
- Applicable for conditions where 1 float can actuate switches at high and low levels.
- FCPV3 Two floats actuate two independent reed switches: Each float unit's default setting can be either N.O. or N.C. as per cus



Magnetisk Nivåvakt Typ Miniflottör Serie FC(D)

www.processcenter.se

HOW TO ORDER PLASTIC SWITCHES

FC **PV1** **2** **D** **A** (**05** **P**)

Order No./ Model

PV1: Vertical Mounting, Single Float Single Switch

PV2: Vertical Mounting, Single Float Dual Switch

PV3: Vertical Mounting, Dual Float Dual Switch

Material of Wetted parts

1: PP; Lead wire---PVC---Temp. 80°C

2: NBR (only float); Lead wire---PVC---Temp. 60°C
Lead wire---XLPE---Temp. 100°C

3: PVDF; Lead wire---XLPE---Temp. 125°C

4: Nylon; Lead wire---XLPE---Temp. 125°C
(Unsuitable for immersion in water for long persisting periods)

Switching Capacity Max.

D: 50W 240Vac /200Vdc SPST 

F: 10W 125Vac SPST

K: 20W 150Vac/200Vdc SPDT

Contact Mode

A: Normally Open (N.O.) SPST

B: Normally Closed (N.C.) SPST

C: SPDT

F: 1 float 2 points.

H: 1-N.O., 1-N.C.(2 floats)

Lead wire Length (Unit=100mm)

05: 500mm (below 500mm) ※ 500mm per Unit

10: 1000mm (501~1000mm) ※ 300mm (Standard length)

15: 1500mm (1001~1500mm)

⋮

Material of Lead wire

C: PVC cable (80°C) ---- AWG22 X ϕ 4

P: PVC (80°C) ---- AWG22 (Standard)

X: XLPE (125°C) ---- AWG22

Magnetisk Nivåvakt Typ Miniflottör Serie FC(D)

www.processcenter.se

CUSTOMIZED STAINLESS STEEL MODELS

Items below are custom-built models for special application and location on existing equipment facilities. Their unique characteristics are as follows:

- Any size measurement range available.

- Customized mounting thread specification are acceptable.
- Single or multiple contact form (point) are workable.
- Switch activation N.O. or N.C. are available.

► FDS□11

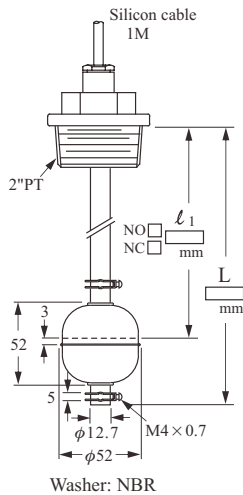

► FDSE□11

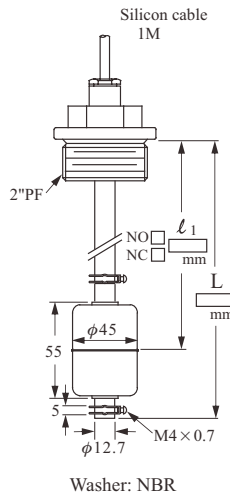

► FDSF□11

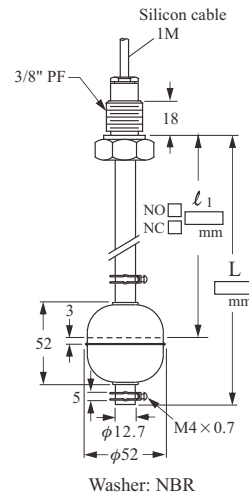

► FD4503D

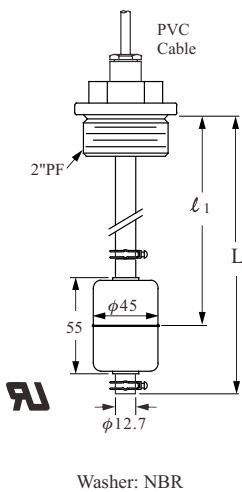

► FD5003G

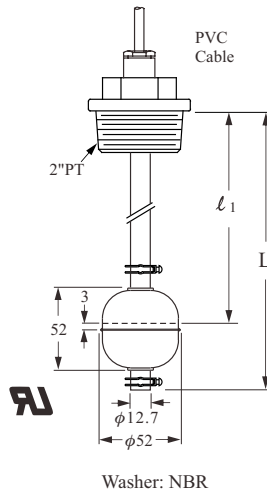

► FD7503G

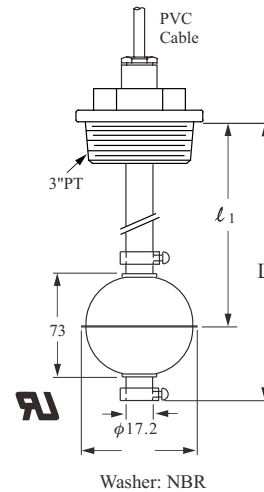



Magnetisk Nivåvakt Typ Miniflottör Serie FC(D)

www.processcenter.se

HOW TO ORDER CUSTOMIZED STAINLESS STEEL MODELS

FD **SA** **6** **1** **2** **D** **A** **05**

Type _____

- FDSA** Float : **RF-SA** ϕ 28x28, Screw : 1/8"PF
- FDSB** Float : **RF-SB** ϕ 28x28, Screw : 1/8"NPT
- FDESC** Float : **RF-SC** ϕ 28x28, Screw : M12
- FDSD** Float : **RF-SD** ϕ 52x52, Screw : 2"PT
- FDSE** Float : **RF-SE** ϕ 45x55, Screw : 2"PF
- FDSF** Float : **RF-SF** ϕ 52x52, Screw : 3/8"PF

Material of Wetted parts _____

- 0** : SUS304
- 6** : SUS316

Mounting _____

- 1** : Top or Bottom Mourting
- 2** : Side Mounting

Float Number _____

1~4 floats

Switching Capacity Max. _____

- D**: 50W 240Vac /200Vdc, SPST
- G**: 60W 220Vac, SPDT (only use for tube ϕ 12.7)
- K**: 20W 150Vac /200Vdc, SPDT

Contact Form _____

- A**: Normal Open (N.O.) SPST **F** : 1 float 2 points
- B**: Normal Close (N.C.) SPST **H**: 1-N.O.,1-N.C.(2 floats)
- C**: 1AB SPDT

Lead wire Length (Unit=100mm) _____

- 03**: 300mm (SA, SB, SC, Standard length) ※ 500mm per Unit
- 05**: 500mm (below 500mm)
- 10**: 1000mm (SD, SE, SF, Standard length)
- 15**: 1500mm (1001~1500mm)

Material of Lead wire _____

- C**: PVC cable (80°C) ---- AWG22 X 2C X ϕ 4
 - F**: SILICON cable (150°C) ---- AWG24 X 2C X ϕ 4
 - P**: PVC (80°C) ---- AWG22
 - T**: TEFLON (200°C) ---- AWG24
 - X**: XLPE (125°C) ---- AWG22 (Standard)
- } For SA, SB, SC Type

Magnetisk Nivåvakt Typ Miniflottör Serie FC(D)

www.processcenter.se

TYPICAL WIRING DIAGRAMS

* AUTO SUPPLY CASE:
SINGLE FLOAT DUAL SWITCHES

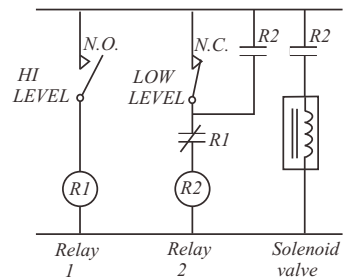
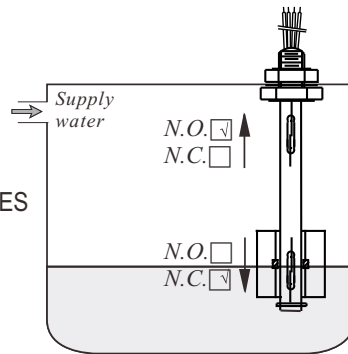

* AUTO DRAIN CASE:
SINGLE FLOAT DUAL SWITCHES

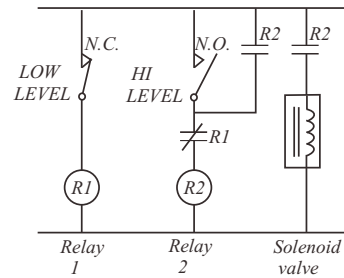
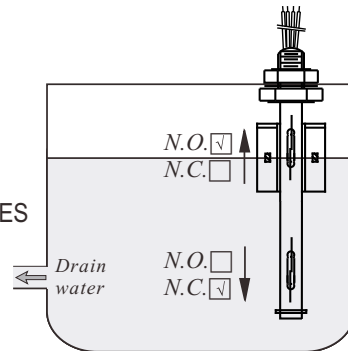

* AUTO SUPPLY CASE:
DUAL FLOATS DUAL SWITCHES

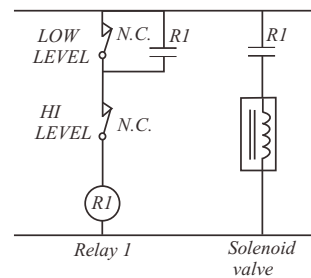
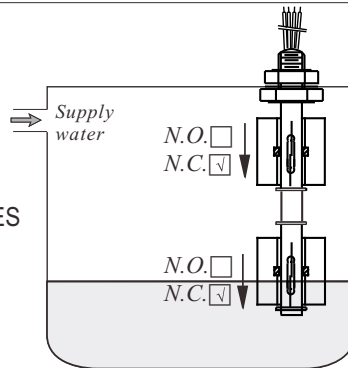

* AUTO DRAIN CASE:
DUAL FLOATS DUAL SWITCHES

