



Process Center AB

RF-Kapacitiv Nivåvakt Serie SB

www.processcenter.se



RF-Kapacitiv nivåvakt serie SB

Process Center AB
Skogsbrynsvägen 8 C
236 31 Höllviken
040 452900 info@processcenter.se



RF-Kapacitiv Nivåvakt Serie SB

PRODUCT INTRODUCTION

PRODUCT DESCRIPTION

RF-Capacitance /Admittance level switch is appropriate for application in liquid and solid mediums. It is designed to reduce medium attaching to the probe. This product also offers DPDT output, high/low level failsafe, adjustable time delay, and sensitivity adjustment. Various models are available for high temperature, or limited space environments.

WORKING PRINCIPLE

RF-Capacitance /Admittance level switch consists of a guard section, upper insulation, main probe and grounding. The guard section is designed to overcome possible medium attachment and to secure signal accuracy. The special structure is suitable for detecting different mediums without being affected by attachments.

The upper main probe, guard, and grounding are all insulated. The level of the medium can be detected by the increasing of admittance when medium reaches the main probe.

The grounding and the main probe are insulated, thus the device will still function accurately and not cause false alarms when the medium attaches the probe.

FEATURES

- Time delay function from 0-30 seconds
- IP65 housing protection
- 5 A/250Vac output DPDT
- High/low failsafe
- Alarm testing
- Explosion Proof model available

FEATURES

- Anti-Viscosity
- Easy Installation
- Stable; Not affected by temperature
- Highest temperature tolerance of 550°C
- Explosion-proof 450°C
- Applicable in liquid, syrup, solid, powder, and surface level detection

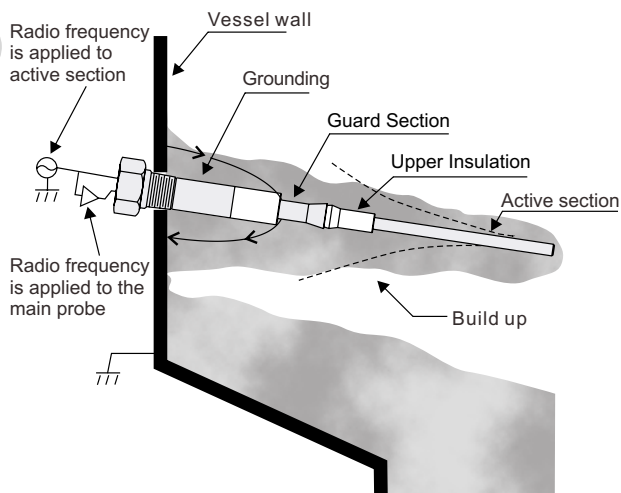



RF-Kapacitiv Nivåvakt Serie SB

www.processcenter.se

CONSTRUCTION & APPLICATION

CONSTRUCTION

1. Main probe: SUS304 or SUS316
2. Upper Insulation: The upper insulated part of the main probe and guard section have very low k die-electric constants and are made of PTFE or PEEK
3. Guard Section: The conductive metal probe helps to dissipate any possible presence of a false signal.
4. Lower Insulation: Due to the low k die-electric constant nature of the main probe, it is comprised of PTFE
5. Connection: 3/4"NPT(Standard model)
6. Housing: Aluminum Alloy Spray Paint
7. Wiring Point: 1/2" PT
8. Waterproof O-Ring: Rubber
9. Circuitry: FSH and FSL, Time Delay Adjustable Function

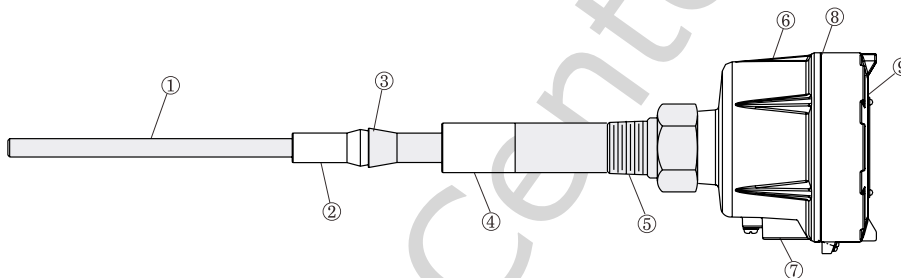

APPLICATION

Storage Tanks, Containers, Wells, Reservoirs and bins containing any liquids, powders or pellets that require precise level detection and control. Key industries include:

- Breweries
- Mining
- Paint Manufacturing Cement
- Coalt
- Food Processing
- Flour Mills
- Glass Industry
- Plastics Engineering, Polymers and synthetics
- Paper Manufacturing
- Power Plants
- Water Treatment and Waste
- Tar
- Food and beverages industries

EXAMPLE

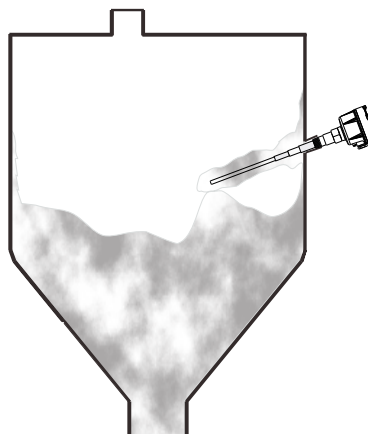

- 2100/2110: Standard Model ----- Applicable to normal environments.
 2200: Hi-Temperature Model -----Applicable to high temperatureerature environments.
 2280: Super Hi-Temperature Model -----Applicable to super high temperatureerature environments.
 2500: Cable Model -----Applicable to big tank and top installation environments.
 2600: Mini Model -----Applicable to space constraint and small tanks.
 17□□: Explosion Proof Type ----- Ex d IIB T6~T1 Gb



RF-Kapacitiv Nivåvakt Serie SB

SPECIFICATIONS

Dimension (Unit:mm)			
Order No.	SB2100 [Standard Model]	SB2110 [Standard Model] SB2120 [Standard L Model]	SB2200 [Hi-Temp Model]
Operating temp.	-40°C~150°C	-40°C~150°C	-40°C~232°C
Ambient temp.	-40°C~70°C	-40°C~70°C	-40°C~70°C
Housing	Aluminum (IP65)	Aluminum (IP65)	Aluminum (IP65)
Probe material	SUS304 or 316	SUS304 or 316	SUS304 or 316
Insulated material	PTFE	PTFE	PEEK
Connection	1" PT	3/4" PT	1" PT
Sensitivity	0.3PF	0.3PF	0.3PF
Supply voltage	24Vdc ± 20% or 115/230Vac ± 10%, 50/60Hz	24Vdc ± 20% or 115/230Vac ± 10%, 50/60Hz	24Vdc ± 20% or 115/230Vac ± 10%, 50/60Hz
Power consumption	Max.2W	Max.2W	Max.2W
Contact rating	5A/250Vac, DPDT	5A/250Vac, DPDT	5A/250Vac, DPDT
Delay time	0~30 sec	0~30 sec	0~30 sec
Fail safe mode	High / low Fail safe mode	High / low Fail safe mode	High / low Fail safe mode
Conduit	1/2" NPT x2 hole	1/2" NPT x2 hole	1/2" NPT x2 hole
Operation pressure	20kg/cm ²	20kg/cm ²	20kg/cm ²



RF-Kapacitiv Nivåvakt Serie SB

www.processcenter.se

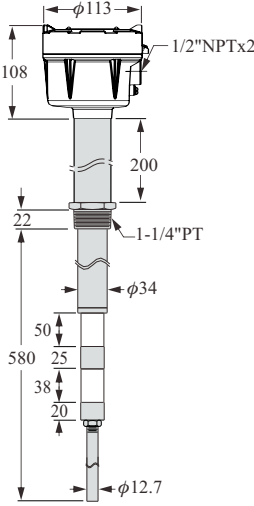
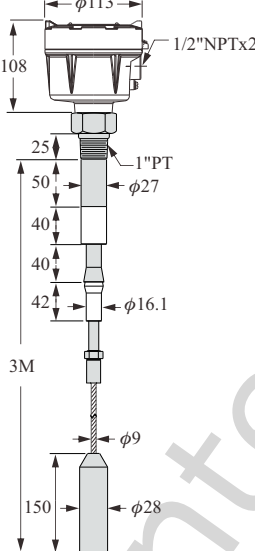
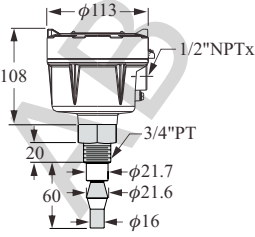
Dimension (Unit:mm)			
Order No.	SB2280 [Super Hi-Temp Model]	SB2500 [Cable Model]	SB2600 [Mini Model]
Operating temp.	-40°C~550°C	-40°C~150°C	-40°C~150°C
Ambient temp.	-40°C~70°C	-40°C~70°C	-40°C~70°C
Housing	Aluminum (IP65)	Aluminum (IP65)	Aluminum (IP65)
Probe material	SUS304 or 316	SUS304 or 316	SUS304 or 316
Insulated material	Ceramic	PTFE	PTFE
Connection	1-1/4" PT	1" PT	3/4" PT
Sensitivity	0.3PF	0.3PF	0.3PF
Supply voltage	24Vdc±20% or 115/230Vac±10%, 50/60Hz	24Vdc±20% or 115/230Vac±10%, 50/60Hz	24Vdc±20% or 115/230Vac±10%, 50/60Hz
Power Consumption	Max.2W	Max.2W	Max.2W
Contact rating	5A/250Vac, DPDT	5A/250Vac, DPDT	5A/250Vac, DPDT
Delay time	0~30 sec	0~30 sec	0~30 sec
Fail safe mode	High / low Fail safe mode	High / low Fail safe mode	High / low Fail safe mode
Conduit	1/2" NPT x2 hole	1/2" NPT x2 hole	1/2" NPT x2 hole
Operation pressure	ATM	20kg/cm ²	20kg/cm ²



RF-Kapacitiv Nivåvakt Serie SB

www.processcenter.se

SPECIFICATION

PTB PROOF NO. 09 ATEX 1057 Ⓢ II 2G Ex d IIB T6~T1 Gb

Ⓢ II 2D Ex tb IIIC T80°C~T445°C Db IP65

Dimension (Unit:mm)			
Order No.	SB1710 [Standard Model]	SB1711 [Standard Model] SB1712 [Standard L Model]	SB1720 [Hi-Temp Model]
Operating temp.	-40°C~150°C	-40°C~150°C	-40°C~232°C
Ambient temp.	-20°C~70°C	-20°C~70°C	-20°C~70°C
Housing	Aluminum (IP65)	Aluminum (IP65)	Aluminum (IP65)
Probe material	SUS304 or 316	SUS304 or 316	SUS304 or 316
Insulated material	PTFE	PTFE	PEEK
Connection	1" PT	3/4" PT	1" PT
Sensitivity	0.3PF	0.3PF	0.3PF
Supply voltage	24Vdc±20% or 115/230Vac±10%, 50/60Hz	24Vdc±20% or 115/230Vac±10%, 50/60Hz	24Vdc±20% or 115/230Vac±10%, 50/60Hz
Power consumption	Max.2W	Max.2W	Max.2W
Contact rating	3A/250Vac, DPDT	3A/250Vac, DPDT	3A/250Vac, DPDT
Delay time	0~30 sec	0~30 sec	0~30 sec
Fail safe mode	High / low Fail safe mode	High / low Fail safe mode	High / low Fail safe mode
Conduit	1/2" NPT x2 hole	1/2" NPT x2 hole	1/2" NPT x2 hole
Operation pressure	20kg/cm ²	20kg/cm ²	20kg/cm ²



RF-Kapacitiv Nivåvakt Serie SB

www.processcenter.se

PTB PROOF NO. 09 ATEX 1057 Ⓢ II 2G Ex d IIB T6~T1 Gb

Ⓢ II 2D Ex tb IIIC T80°C~T445°C Db IP65

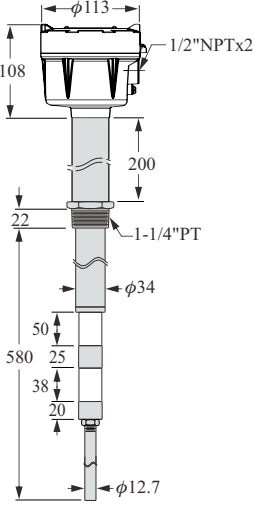
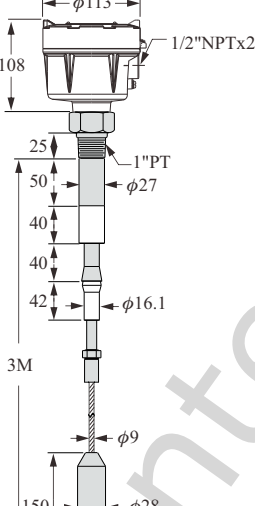
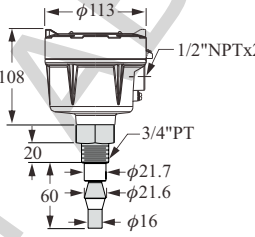
Dimension (Unit:mm)			
Order No.	SB1728 [Super Hi-Temp Model]	SB1750 [Cable Model]	SB1760 [Mini Model]
Operating temp.	-40°C~450°C	-40°C~150°C	-40°C~150°C
Ambient temp.	-20°C~70°C	-20°C~70°C	-20°C~70°C
Housing	Aluminum (IP65)	Aluminum (IP65)	Aluminum (IP65)
Probe material	SUS304 or 316	SUS304 or 316	SUS304 or 316
Insulated material	Ceramic	PTFE	PTFE
Connection	1-1/4" PT	1" PT	3/4" PT
Sensitivity	0.3PF	0.3PF	0.3PF
Supply voltage	24Vdc±20% or 115/230Vac±10%, 50/60Hz	24Vdc±20% or 115/230Vac±10%, 50/60Hz	24Vdc±20% or 115/230Vac±10%, 50/60Hz
Power consumption	Max.2W	Max.2W	Max.2W
Contact rating	3A/250Vac, DPDT	3A/250Vac, DPDT	3A/250Vac, DPDT
Delay time	0~30 sec	0~30 sec	0~30 sec
Fail safe mode	High / low Fail safe mode	High / low Fail safe mode	High / low Fail safe mode
Conduit	1/2" NPT x2 hole	1/2" NPT x2 hole	1/2" NPT x2 hole
Operation pressure	ATM	20kg/cm ²	20kg/cm ²



WIRING DIAGRAMS

DESCRIPTION OF PANEL FUNCTION

- ① Set Point: Clockwise, capacitance increases.
- ② Red LED: Power indicator.
- ③ Range: Alarm setting- HI/LOW
- ④ FSH/FSL switch (High/Low level failsafe)
- ⑤ Green LED: Alarm indicator for FSH and FSL.
Green LED turns off when alarm goes off.
- ⑥ Time Delay: Alarm time delay setting up to 30 seconds.
- ⑦ Alarm simulation testing.(SB2□□□A series)
- ⑧ Relay output.
- ⑨ Power: 115/230Vac

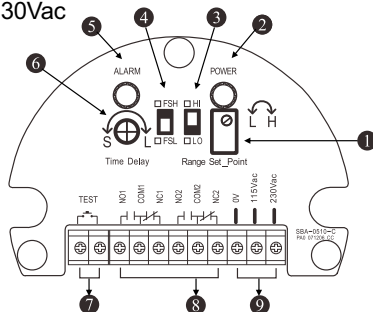

FAILSAFE ALARM

FSH high level failsafe alarm:

SB2□□□ series switch is installed at the high level point the FSH switch mode is "on".

When the medium has no contact with the probe, the green LED lights up and relay output COM/NC is in an open state.

When the medium level reaches high level and it touches the probe (or in the case of blackout), the green LED turns off and the relay output COM/NC is closed. When the relay output COM/NC is closed, it implies the FSH alarm has been activated.

ALARM CALIBRATION

Setting for High Level Alarm

1. Switch the FSH/FSL Knob to FSH
2. Switch the Range Knob to LO.
3. Switch the Time Delay Knob to S (Minimum).
4. Decreasing the level of the medium to below the measuring probe.
5. Spinning the Set Point Knob till the Alarm LED (green light) lights up.
6. Firstly, increasing the level of the medium till it covers half of the measuring probe and the Alarm LED (green light) shut off. Secondly, spinning the Set Point Knob clockwise till Alarm LED (green light) lights up. If the Alarm LED (green light) still not lights up after spinning it till the end, please adjust the Range Switch to HI and repeat procedure 5. Thirdly, recording the numbers of turns and its angle, then switching the knob counterclockwise back for 1/2 circle and angle.
7. Adjusting the delay time for alarm (0~30 seconds): If turning the Time Delay Knob clockwise, the delay time is postponed, while turning the Time delay Knob counterclockwise,

DESCRIPTION OF PANEL FUNCTION

- ① Set Point: Clockwise, capacitance increases.
- ② Red LED: Power indicator.
- ③ Range: Alarm setting- HI/LOW
- ④ FSH/FSL switch (High/Low level failsafe)
- ⑤ Green LED: Alarm indicator for FSH and FSL.
Green LED turns off when alarm goes off.
- ⑥ Time Delay: Alarm time delay setting up to 30 seconds.
- ⑦ Alarm simulation testing.(SB2□□□B series)
- ⑧ Relay output.
- ⑨ Power: 24Vdc.

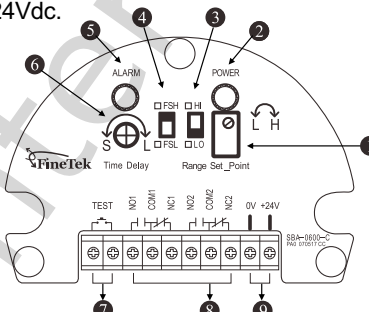

FSL low level failsafe alarm:

SB2□□□ series switch is installed at the low level, the FSL mode is "on".

When the medium touches the probe the green LED lights up and the relay output COM/NC is in an open state.

When the medium level drops below the low level and the medium does not have contact with the probe (or in the case of blackouts), the green LED turns off and relay output COM/NC is closed.

When relay output COM/NC is closed, it implies the FSL alarm has been activated.

Setting for Low Level Alarm

1. Move the FSH/FSL button to FSL.
2. Move the 'range' button to LO.
3. Turn the 'time delay' knob to S (Minimum).
4. Lower the level of the medium to cover half of the measuring probe.
5. Turn the 'set point' screw counterclockwise till the Alarm LED lights up. If the LED hasn't lit up after turning it fully to the end, please adjust the 'range' button to HI and repeat procedure 5.
6. Now, decrease the level of the medium until it is below the measuring probe and the Alarm LED has turned off.
Next, turn the 'set point' screw counterclockwise until the Alarm LED (green light) lights up [Recording the numbers of turns you make]. Finally, turn back the 'set point' screw clockwise for 1/2 circle.
7. Adjust the delay time for the alarm (0~30 seconds):
When turning the 'time delay' knob clockwise, the delay time is postponed. Turning the 'time delay' knob counterclockwise, the delay time will be shortened.



RF-Kapacitiv Nivåvakt Serie SB

www.processcenter.se

HOW TO ORDER

SB 2

Order No. _____

- 10:** Standard Model(1"PT)
- 11/12:** Standard Model/Standard LModel(3/4"PT)
- 20:** Hi-Temperature Model(232°C)
- 28:** Super Hi-Temperature Model(550°C)
- 50:** Cable Model
- 60:** Mini Model

MATERIAL _____

0: SUS304 **6:** SUS316 **L:** SUS316L

POWER _____

- A:** 115/230Vac 10%, 50/60Hz--- Analog alarm function
- B:** 24Vdc 20%--- Analog alarm function
- C:** 115/230Vac 10%, 50/60Hz
- D:** 24Vdc 20%

Connection _____

Dimension		Specification	
C---3/4"(20A)*	H---3"(80A)	M---5kg/cm ²	Z---PN 40
D---1"(25A)	I---4"(100A)	N---10kg/cm ²	Q---PT
3---1-1/4"(32A)	J---5"(125A)	O---150 Lbs	R---PF
E---1-1/2"(40A)	K---6"(150A)	P---300 Lbs	T---BSP
F---2"(50A)	S---Others	W---PN 10	U---NPT
G---2-1/2"(65A)		X---PN 16	V---GAS
		Y---PN 25	S---Others

*3/4" connection is only available for SB2100, 2110, 2120, 2600.

Probe Length (unit: mm) _____

- 0500:** below 500mm
- 1000:** 501~1000mm
- 1500:** 1001~1500mm
- ⋮
- ⋮

- ※ 500mm per Unit
- ※ Use letters for the code beginning for probelengths over 10m.
A150 represents 15m, A200 represents 20m

- * Margin of error of the total product length is ±5mm.
- * Characteristics, specifications and dimensions are subject to change.
- * Please contact your nearest distributor for further information.



RF-Kapacitiv Nivåvakt Serie SB

www.processcenter.se

HOW TO ORDER

SB17

Order No. _____

- 10:** Explosion Proof Standard Model(1"PT)
- 11/12:** Explosion Proof Standard Model /Standard LModel(3/4"PT)
- 20:** Explosion Proof Hi-Temperature Model(232°C)
- 28:** Explosion Proof Super Hi-Temperature Model (450°C)
- 50:** Explosion Proof Cable Model
- 60:** Explosion Proof Mini Model

MATERIAL _____

0: SUS304 **6:** SUS316 **L:** SUS316L

POWER _____

- A:** 115/230Vac ± 10%, 50/60Hz---Analog alarm function
- B:** 24Vdc ± 20%---Analog alarm function
- C:** 115/230Vac ± 10%, 50/60Hz
- D:** 24Vdc ± 20%

Connection _____

Dimension		Specification	
C---3/4"(20A)*	H---3"(80A)	M---5kg/cm ²	Z---PN 40
D---1"(25A)	I---4"(100A)	N---10kg/cm ²	Q---PT
3---1-1/4"(32A)	J---5"(125A)	O---150 Lbs	R---PF
E---1-1/2"(40A)	K---6"(150A)	P---300 Lbs	T---BSP
F---2"(50A)	S---Others	W---PN 10	U---NPT
G---2-1/2"(65A)		X---PN 16	V---GAS
		Y---PN 25	S---Others
*3/4" connection is only available for SB1711, 1712, 1760.			

Probe Length (unit: mm) _____

- 0500:** below 500mm
- 1000:** 501~1000mm
- 1500:** 1001~1500mm
- ⋮
- ⋮

- ※ 500mm per Unit
- ※ Use letters for the code beginning for probe lengths over 10m.
A150 represents 15m, A200 represents 20m

- * Margin of error of the total product length is ±5mm.
- * Characteristics, specifications and dimensions are subject to change.
- * Please contact your nearest distributor for further information.