

# Dränkbar Kapacitiv Nivågivare LMP633-NCN Keramiskt membran

www.processcenter.se

## Product introduction

## Description



Standard



Anti-corrosive

**Submersible level transmitter**

LMP633 Submersible level transmitter is designed for dealing with the most severe demanding level measurement conditions. The sensor adopts the most advanced micro-processor technology with comprehensive linear error compensation and temperature error compensation to assure the highest precision of measuring result. The probe adopts full potting condensation-preventing technology, safe and reliable dual-seal design and fully welding technology with solid stainless steel body to assure long term stability and permanent air tightness. Signal transmitting module adopts transient voltage resistance protective circuits to assure operation regularly even under the harsh surge voltage environment. The seal of the cable adopts intensive cone plug sealing design to assure the long working life even under large mechanical load conditions during the installation and long-term use. LMP633 Submersible level transmitter is the optimal choice to satisfy all of high demand level measuring applications.

## Main parameters

Pressure types	Gauge pressure
Measuring range	1mH <sub>2</sub> O - 200mH <sub>2</sub> O, Please refer to the ordering information chapter
Output signal	4-20mA, 4-20mA+HART, 0.5-4.5VDC Modbus-RTU/RS485, others
Reference accuracy	±0.2% URL, ±0.5% URL

## Application

Level measurement in container, others

## Approvals



## Measuring medium

Water, waste water, oil

# Dränkbar Kapacitiv Nivågivare LMP633-NCN Keramiskt membran

www.processcenter.se

## Technical specifications

### Measuring range and limit

Nominal value	Smallest calibratable span	Lower range limit (LRL)	Upper range limit (URL)	Overload limit
20kPa	10kPa	0kPa	20kPa	600kPa
40kPa	20kPa	0kPa	40kPa	600kPa
100kPa	40kPa	0kPa	100kPa	1MPa
200kPa	100kPa	0kPa	200kPa	1.8MPa
400kPa	200kPa	0kPa	400kPa	2.5MPa
1MPa	400kPa	0kPa	1MPa	4MPa
2MPa	1MPa	0kPa	2MPa	4MPa

The unit of the measuring range above can be converted into mH<sub>2</sub>O@4°C, mmH<sub>2</sub>O@4°C, inH<sub>2</sub>O@4°C, m, mm and mHg@0°C. Please provide the density of measuring medium if the unit is m, mm. Other measuring range is available according to requirements. (1MPa=102mH<sub>2</sub>O@4°C)

### Standard specifications and reference conditions

Test standard: GB/T28474 / IEC60770 Zero based-calibration span.

### Power supply effects

Zero and span change should not be more than  $\pm 0.005\%$  URL/V

### Performance specifications

The overall performance including but not limited to **【reference accuracy】**, **【environment temperature effects】** and other comprehensive error

Typical accuracy:  $\pm 0.2\%$  URL (with HART protocol:  $\pm 0.1\%$  URL)

Stability:  $\pm 0.2\%$  URL/ year

### Loading effects

Zero and span change should not be more than  $\pm 0.05\%$  URL/k $\Omega$

### Vibration effects

According to IEC61298-3/GB/T 18271.3 testing 20g (5-2000HZ, Max imum vibration value < 3mm)

### Reference accuracy

Including linearity(BFSL), hysteresis and repeatability. calibration temperature: 20 °C  $\pm$  5 °C

Linear output accuracy	Typical	$\pm 0.2\%$ URL (HART output accuracy: $\pm 0.1\%$ URL)	Nominal value: 20kPa, 40kPa, 100kPa, 200kPa, 400kPa, 1MPa, 2MPa
	Max/ Voltage output	$\pm 0.5\%$ URL	

### Output signal

Signal	Type	Output
4-20mA	Linearity	Two wire
4-20mA+HART	Linearity	Two wire
0.5-4.5VDC	Linearity	Three wire
Modbus-RTU/RS485	Linearity	Four wire

### Ambient temperature effects

Within the range - 20-80 °C total impact  $\pm 0.2\%$ URL/10k

### Insulation resistance

$\geq 20M\Omega@, 100VDC$

## Dränkbar Kapacitiv Nivågivare LMP633-NCN Keramiskt membran

www.processcenter.se

### Performance specifications

#### Damping time

Total damping time constant: equal to the sum of damping time of amplifier and sensor capsule
Damping time of amplifier : 0-100S adjustable
Startup after power off : ≤3S (HART output time: ≤ 6S)
Normal services after data recovery : ≤31S

#### Environment condition

Items	Operational condition
Working temperature	-10-70°C
Storage temperature	-30-80°C
Media temperature	-10-70°C
Protection class	IP68

### Technical Specifications

Signal output	4-20mA	4-20mA+HART*	0.5-4.5VDC	0.5-4.5VDC(ratiometric output)	RS485
Power supply	10-30VDC	10.5/16.5-55VDC	6-15VDC	5VDC	5VDC/9-30VDC
Allowed current	≤20.8mA		≤3.5mA		≤7mA
Load resistance(Ω)	<(U-10)/0.0208	<(U-10.5)/0.0208**	≥5k, recommend 100k		/
Transmission distance	<1000m		<5m		<1200m
Power consumption	≤500mW(20.8mA output@24VDC)		≤17.5mW(0.5-4.5VDC output@5VDC)		≤168mW(RS485 output@24VDC)

\*For this output type, the load resistance value in communication is 250Ω

\*\*The load resistance value 0-2119Ω is in nominal working condition, 250-600Ω is for HART communication

### EMC environment (not for RS485 signal output)

NO.	Test items	Basic standards	Test conditions	Performance level
1	Radiated interference	GB/T 9254/CISPR22	30MHz-1000MHz	OK
2	Conducted interference (DC power port)	GB/T 9254/CISPR22	0.15MHz-30MHz	OK
3	Electrostatic discharge immunity test (ESD)	GB/T 17626.2/IEC61000-4-2	4kV(Contact), 8kV(Air)	B(Note2)
4	Immunity to radio frequency EM-fields	GB/T 17626.3/IEC61000-4-3	10V/m(80MHz-1GHz)	A(Note1)
5	Power frequency magnetic field Immunity test	GB/T 17626.8/IEC61000-4-8	30A/m	A(Note1)
6	Electrical fast transient / Burst Immunity Test	GB/T 17626.4/IEC61000-4-4	2kV(5/50ns, 100kHz)	B(Note2)
7	Surge immunity requirements	GB/T 17626.5/IEC61000-4-5	1kV(Line to line) 2kV(Line to ground) (1.2us/50us)	B(Note2)
8	Immunity to conducted disturbances induced by radio frequency fields	GB/T 17626.6/IEC61000-4-6	3V(150kHz-80MHz)	A(Note1)

(Note 1)Performance level A: The performance within the limits of normal technical specifications.

(Note 2)Performance level B: Temporary reduction or loss of functionality or performance, it can restore itself. The actual operating conditions, storage and data will not be changed.

# Dränkbar Kapacitiv Nivågivare LMP633-NCN Keramiskt membran

www.processcenter.se

## Product selection instruction

### Sensor select instruction

Code	Nominal value	Description
C203G	20kPa	Range 0-20kPa Smallest calibratable span 10kPa
C403G	40kPa	Range 0-40kPa Smallest calibratable span 20kPa
C104G	100kPa	Range 0-100kPa Smallest calibratable span 40kPa
C204G	200kPa	Range 0-200kPa, Smallest calibratable span 100kPa
C404G	400kPa	Range 0-400kPa Smallest calibratable span 200kPa
C105G	1MPa	Range 0-1MPa Smallest calibratable span 400kPa
C205G	2MPa	Range 0-2MPa Smallest calibratable span 1MPa

Adjust requirements: lower range value (LRV) and upper range value (URV) can be adjusted within the scope of the upper and lower range limit, minimum measuring range ≤ |URV - LRV| ≤ maximum measuring range

Code	Position	Instruction
C	Diaphragm material	Ceramic (AL <sub>2</sub> O <sub>3</sub> , content 99.9% )
N	Isolated filling fluid	None
S	Sensor seal	O-ring, FKM (temperature range: -20-200°C)

### Seal (S)

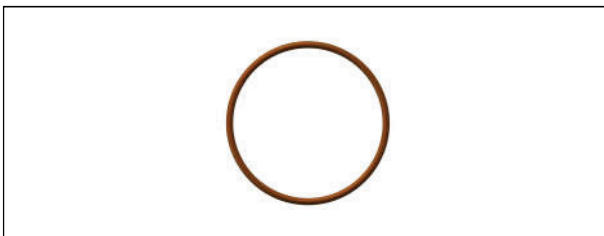

### Electrical connection

Code	Item	Description
N1	Electrical connection	PUR cable, outer diameter: (7.5±0.2)mm
N2		PTFE cable, outer diameter: (7.5±0.2)mm

### Cable(N1/N2)

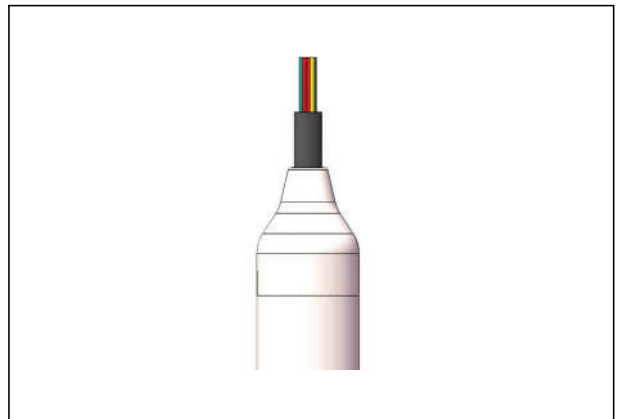

### Electrical connection

#### Cable output

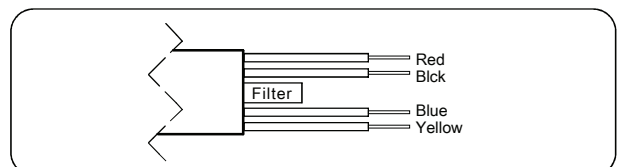

Label	Two wires	Three wires	Four wires	Modbus-RTU/RS485
Red	Power+	Power+	Power+	Power+
Black	Power-	Power-	Power-	Power-
Blue		Signal+	Signal+	A+
Yellow			Signal-	B-

**⚠** The reference pressure of the gauge pressure transmitter is current atmospheric pressure.  
Please operate with care, prevent the filter dropping off and keep it dry.

# Dränkbar Kapacitiv Nivågivare LMP633-NCN Keramiskt membran

www.processcenter.se

## Product selection instruction

### Transmission module

Code	Description
F	4-20mA two wire, power supply: 10-30VDC
H	4-20mA+HART two wire, power supply: 16.5-55VDC
5	0.5-4.5VDC three wire, power supply: 6-15VDC
6	0.5-4.5VDC ratiometric output three wire, power supply: 5VDC
R	Modbus-RTU/RS485, four wire, power supply: 5VDC/9-30VDC

### Fixed mounting accessory

Code	Items	Details
P2	Fixed mounting	Cable clamp(to fix and support the whole product)
P3		Thread mounting accessory(to fix the top of the product and support the whole product)
P5/P6		Counter weight(to fix products in fast flow rate area/large density medium)

Cable clamp(P2)、thread mounting accessory(P3)、counter weight(P5/P6)

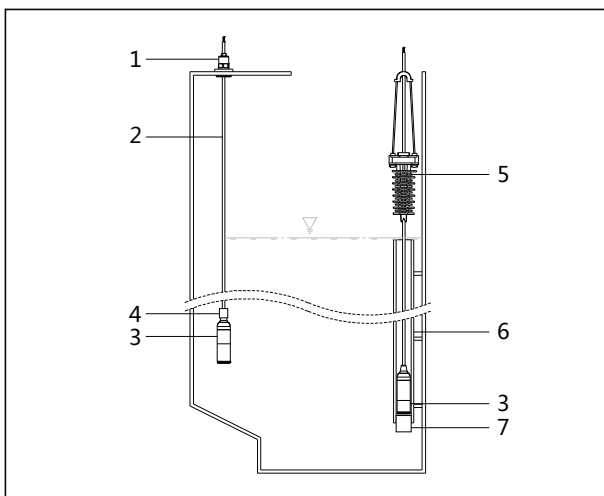

- 1.Thread connection(P3)
- 2.Cable
- 3.Level transmitter
- 4.Counter weight(P5)\*
- 5.Cable clamp(P2)
- 6.Protection sleeve
- 7.Counter weight(P6)\*

\* The measurement results should consider the height error of counter weight and sensing diaphragm to the bottom of measured medium

### Electrical connection

Code	Item	Description
2	Material	PP(maximum measuring range 2MPa)
5		PVDF(maximum measuring range 2MPa)
6		SUS316(maximum measuring range 2MPa)
H39	Specification	Submersible probe outer diameter 39mm(only suitable for SUS316)
H46		Submersible probe outer diameter 46mm(only suitable for PP、PVDF)

### Probe sketches(H39、H46)

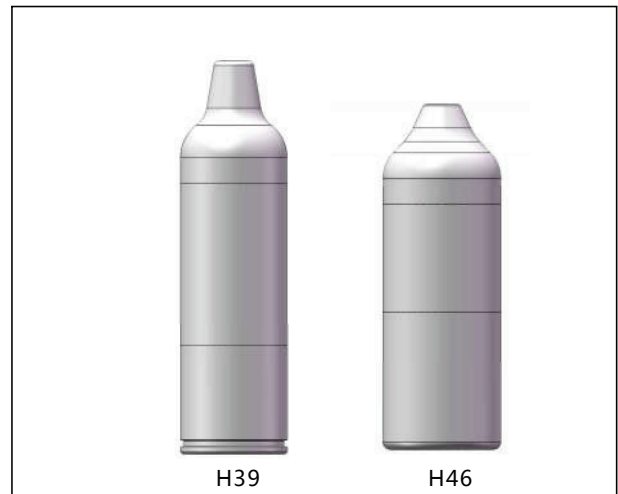

# Dränkbar Kapacitiv Nivågivare LMP633-NCN Keramiskt membran

www.processcenter.se

## Product drawing and dimension

### Standard product drawing and dimension(unit: mm)

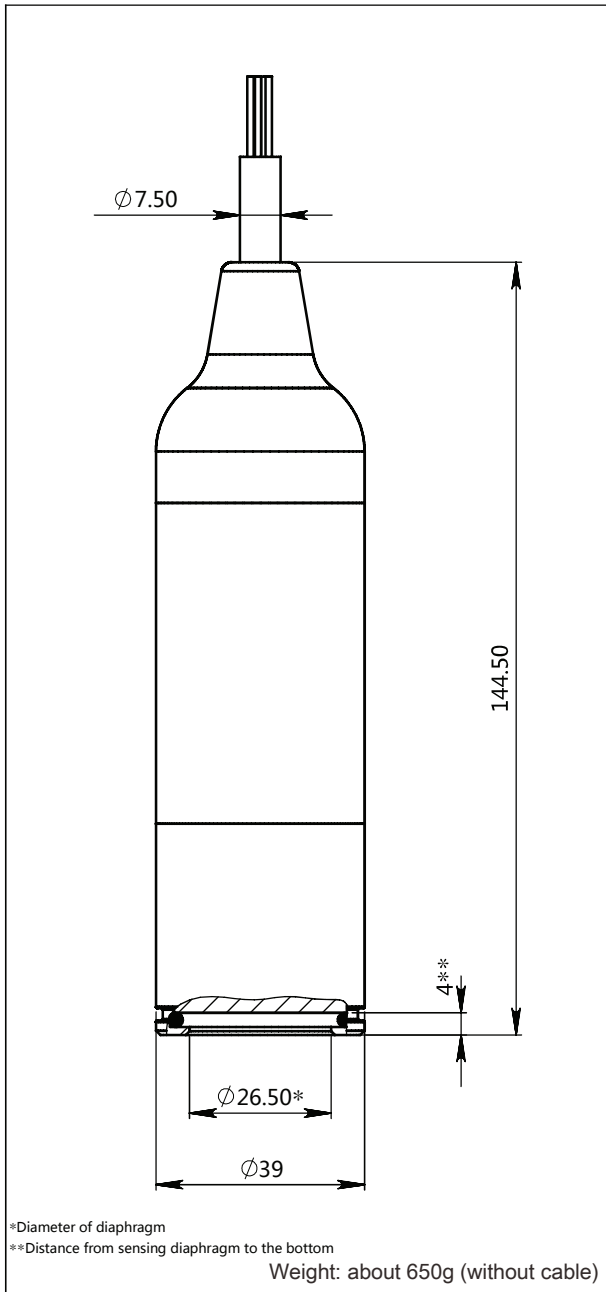

### Anti-corrosive product drawing and dimension(unit: mm)

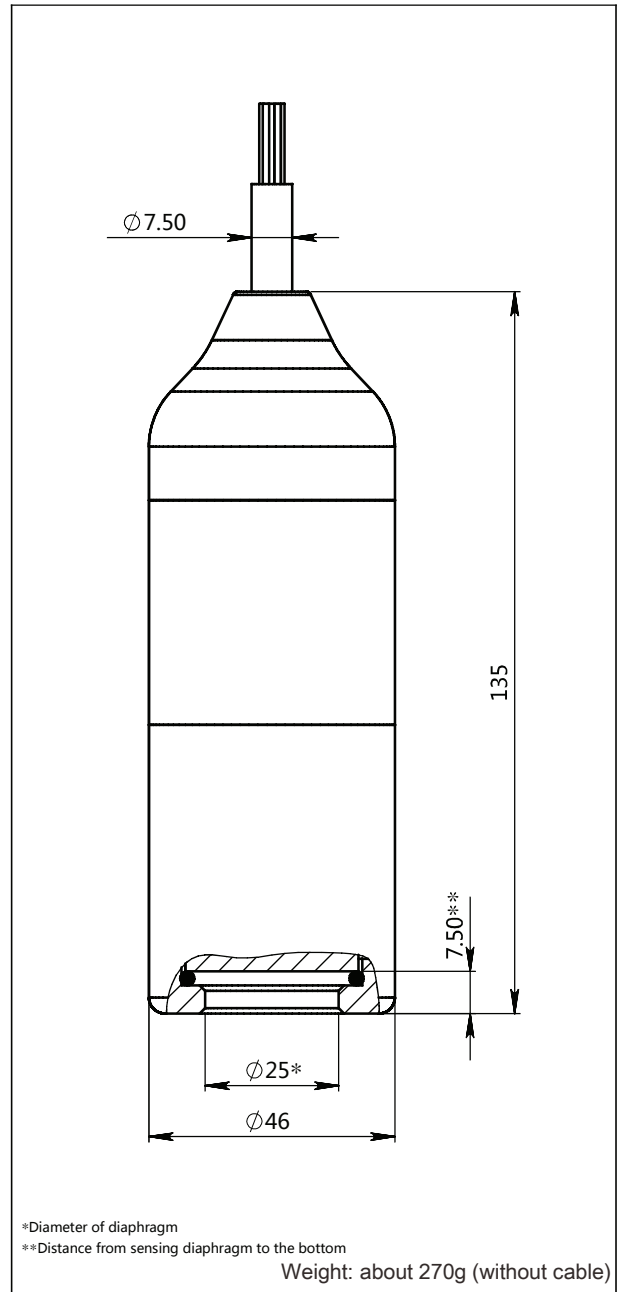

### Corresponding weight of cable with different material

Cable material	Weight/5m(kg)
PUR	0.32
PTFE	0.41

# Dränkbar Kapacitiv Nivågivare LMP633-NCN Keramiskt membran

www.processcenter.se

## Product drawing and dimension

### Cable clamp (P2) dimension (unit: mm)

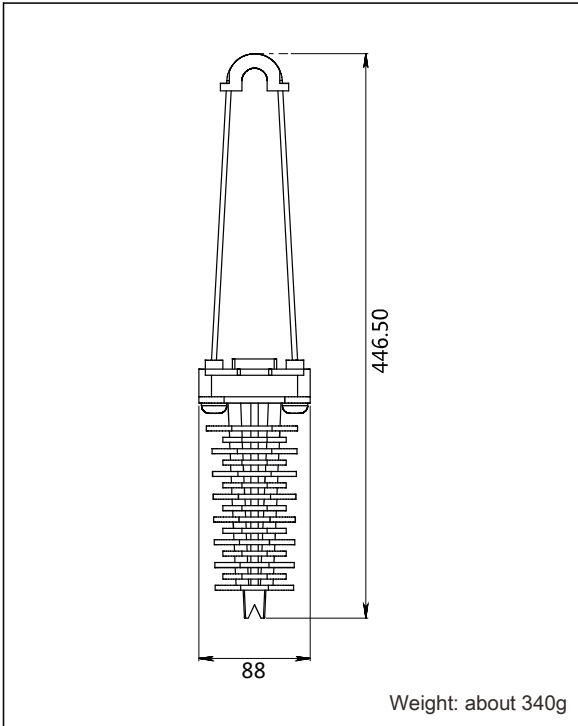

### Counter weight (P5) dimension (unit: mm)

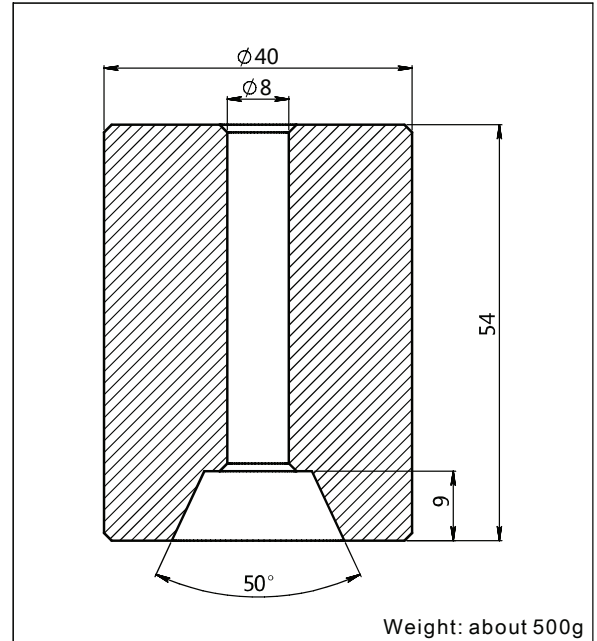

In order to prevent measurement errors caused by sideways movement of product and ensure accuracy, you can add additional counter weights by screwing together and then connecting directly to the product. Each product can be added three counter weights at the most.

### Thread mounting accessory (P3) dimension (unit: mm)

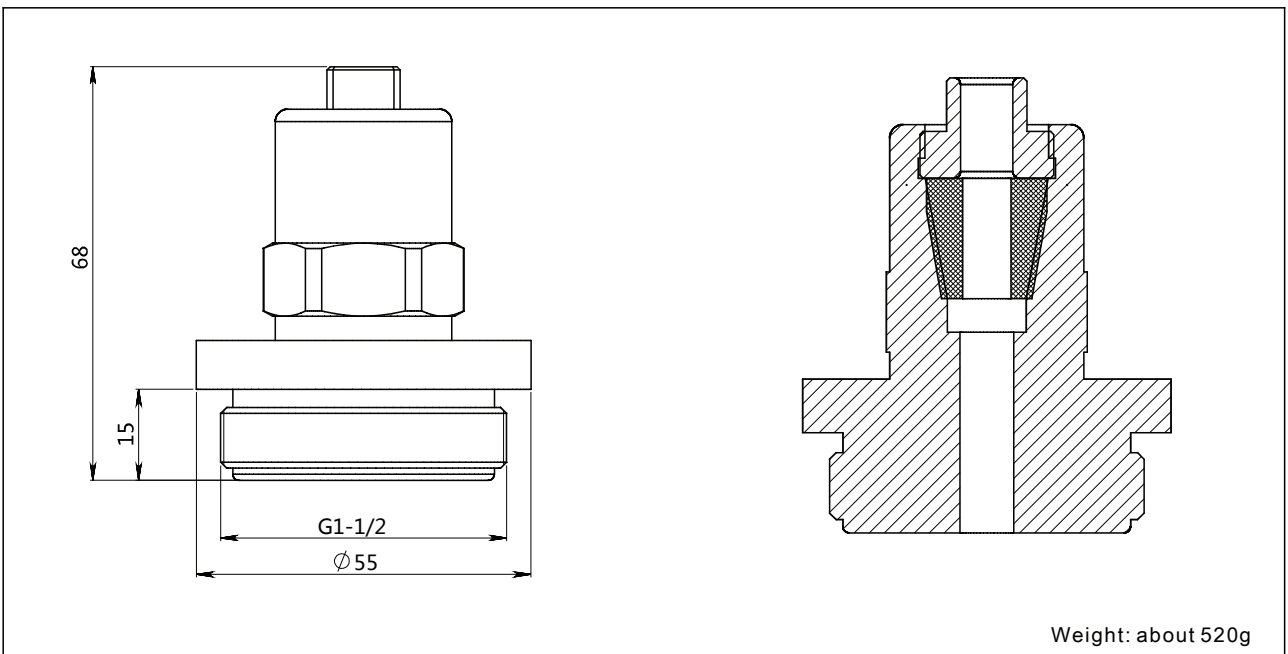

## Dränkbar Kapacitiv Nivågivare LMP633-NCN Keramiskt membran

www.processcenter.se

### Product drawing and dimension

### Counter weight (P6) dimension(unit:mm)

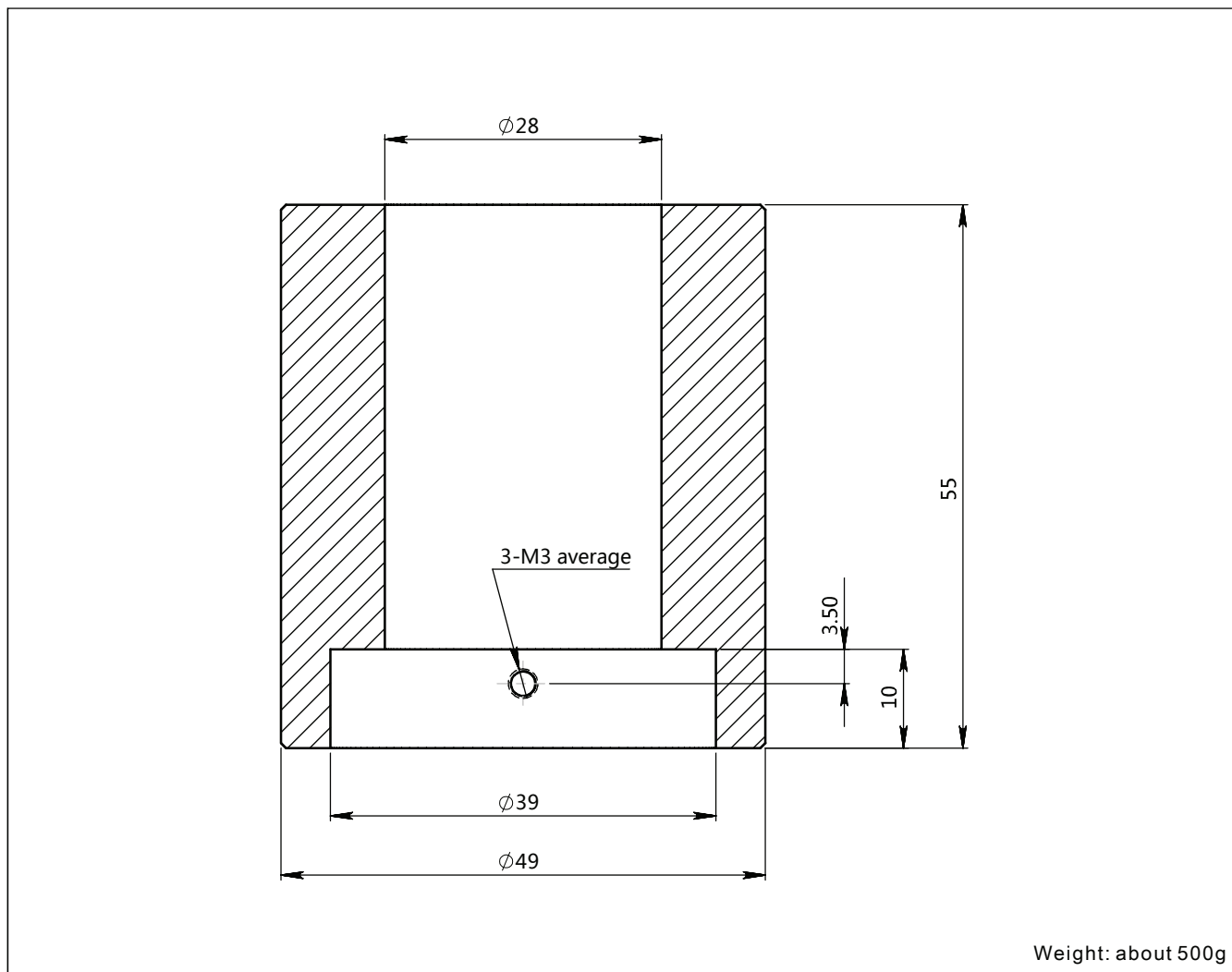

In order to prevent measurement errors caused by sideways movement of product and ensure accuracy, you can add additional counter weights by screwing together and then connecting directly to the product. Each product can be added three counter weights at the most.



## Dränkbar Kapacitiv Nivågivare LMP633-NCN Keramiskt membran

www.processcenter.se

### Ordering information chapter

Item	Parameters	Code	Instruction	(*) fast delivery available
	Model	LMP633-NCN	Capacitive ceramic submersible level transmitter	
Sensor	Separator	-	Detailed specifications as following	
	Pressure range code	C203G	Nominal value(URL): 20kPa	
		C403G	Nominal value(URL): 40kPa	
		C104G	Nominal value(URL): 100kPa	*
		C204G	Nominal value(URL): 200kPa	*
		C404G	Nominal value(URL): 400kPa	*
		C105G	Nominal value(URL): 1MPa	*
		C205G	Nominal value(URL): 2MPa	*
	Diaphragm material	C	Ceramic (AL <sub>2</sub> O <sub>3</sub> , content 99.9% )	*
	Filling fluid	N	None	*
	Sensor seal	S	O-ring, FKM (temperature range: -20-200°C)	*
Electrical connection	Separator	-	Detailed specifications as following	
	Electrical connection	N1	PUR cable, outer diameter: (7.5±0.2)mm	*
		N2	PTFE cable, outer diameter: (7.5±0.2)mm	
	Cable entry protector	R0	None	*
Output	Separator	-	Detailed specifications as following	
	Output signal	F	4-20mA two wire, power supply: 10-30VDC	*
		H	4-20mA+HART two wire, power supply: 16.5-55VDC	
		R	Modbus-RTU/RS485 four wire, power supply: 5VDC/9-30VDC	
		G	Modbus-RTU/RS485 four wire (with pressure and temperature signal), power supply: 5VDC/9-30VDC	
Probe	Separator	-	Detailed specifications as following	
	Material	2	PP(maximum measuring range 2MPa)	
		5	PVDF(maximum measuring range 2MPa)	*
		6	SUS316	*
	Specification	H46	Submersible probe outer diameter 46mm(only suitable for PP、PVDF)	*
		H39	Submersible probe outer diameter 39mm (only suitable for SUS316)	*
Cable	Separator	-	Detailed specifications as following	
	Cable length	Ln	0 ≥ n ≤ 200, Eg. 5 m=L5, 10m = L10, 100m=L100. Allowed error range: 0-0.2m.	*
Additional options	Separator	-	Detailed specifications as following	
	Fixed mounting accessory	P2	Cable clamp(to fix and support the whole product)	
		P3	Thread mounting accessory(to fix the top of the product and support the whole product)	

## Dränkbar Kapacitiv Nivågivare LMP633-NCN Keramiskt membran

www.processcenter.se

### Ordering information chapter

		P5	Counter weight (to fix products in fast flow rate area/large density medium), applied to anti-corrosive type	
		P6	Counter weight (to fix products in fast flow rate area/large density medium), applied to standard type	
	Calibration report	/Q1	Calibration report provided by our company	*
	Approvals (multiple)	/F3	CE certificate	
	Wetted parts treatment	/G1	Ungrease treatment	
		/G2	Electropolishing treatment	

### Approvals

#### Factory certificate

Certification organization	Intertek
Quality management system	ISO9001-2008
Scope of certification	Design and production of pressure transmitter
Registration number	110804039

#### CE

Certificate organization	ISET
License scope	LMP633 submersible pressure transmitter
Mark	CE
EMC instruction	2014/30/EU
Standard	EN61326-1: 2013
Registration number	IT021353LG161207