

## Kompakt Tryckgivare Ekonomi SMP131-TSD-S

www.processcenter.se

### Product introduction

### Description



### Most cost-effective pressure transmitter

SMP131 compact pressure transmitter combined with all the latest available technologies of the modern electronic pressure measurement fields. It's the most cost-effective products after 10 year's research and development. The sensor adopts full-automatic linear and temperature compensation technology to ensure the efficiency and quality of mass production. Fully-sealed and isolated air cavity design to ensure the long term reliability. Signal transmitting module adopts original calibration technology to realize parameters setting easily without any tools. SMP131 compact pressure transmitter has unique technological advantage which is different from other ordinary products with the same price and its' capabilities are equivalent to the most of the high-end products, which is the first selection of the most cost-effective products.

### Main parameters

Pressure types	Gauge pressure
Measuring range	2kPa-40Mpa, please refer to the ordering information chapter
Output signal	4-20mA, 4-20mA+HART, 0-5VDC, Modbus-RTU/RS485, others
Reference accuracy	±0.1% URL, optional ±0.075% URL

### Field of application

Pressure, Level

### Approvals



### Measuring medium

The fluids which compatible with wetted parts

## Kompakt Tryckgivare Ekonomi SMP131-TSD-S

www.processcenter.se

### Technical specifications

#### Measuring range and limit

Nominal value	Smallest calibratable span	Lower range limit(LRL)*	Upper range limit (URL)	Over load limit
40kPa	2kPa	-40kPa	40kPa	1MPa
250kPa	12.5kPa	-100kPa	250kPa	4MPa
1MPa	50kPa	-100kPa	1MPa	6MPa
3MPa	150kPa	-0.1MPa	3MPa	15MPa
10MPa	500kPa	-0.1MPa	10MPa	20MPa
40MPa	5MPa	-0.1MPa	40MPa	80MPa

The unit of the measuring range above can be converted into kg/cm<sup>2</sup>, MPa and kPa. Provide other measuring range according to requirements. Adjust requirements: lower range value (LRV) and upper range value (URV) can be adjusted within the scope of the upper and lower range limit, minimum measuring range ≤ | URV - LRV | ≤ maximum measuring range.

\*The actual lower range limit(LRL) is only approximately zero but can not reach absolute zero. Zero value can be calculated.

#### Standard specifications and reference conditions

Test standard: GB/T28474 / IEC60770; Zero based-calibration span, Linear output, Silicone oil filling, 316L stainless steel isolated diaphragm.

#### Performance specifications

The overall performance including but not limited to 【reference accuracy】, 【environment temperature effects】 and other comprehensive error

Typical accuracy: ±0.1% URL

Stability: ±0.1% URL/ year

#### Reference accuracy

Including linearity, hysteresis and repeatability. calibration temperature: 20 °C ± 5 °C

Linear output accuracy	TD≤10 (note1)	±0.1%URL	Nominal value: 40kPa , 250kPa 1MPa, 3MPa 10MPa, 40MPa
	10<TD≤20	±0.01TD%URL	

Note: TD (Turn Down)  
TD=URL/ | URV-LRV |

#### Ambient temperature effects(Typical)

Within the range -20-80 °C total impact ±0.2%URL/10k

#### Power supply effects

Zero and span change should not be more than ± 0.005% URL/V

#### Loading effects

Zero and span change should not be more than ± 0.05% URL/kΩ

#### Vibration effects

Vibration resistance According to IEC60068-2-6 , 10g RMS (25-2000Hz)

Impact resistance According to IEC60068-2-27 , 500g/1ms

#### Output signal

Signal	Type	Output
4-20mA	Linearity	Two wire
4-20mA+HART	Linearity	Two wire
0-5VDC	Linearity	Three wire
Modbus-RTU/RS485	Linearity	Four wire

#### Working life

10 million max pressure circulation

#### Insulation resistance

≥ 20M Ω@ reference, 100VDC

## Kompakt Tryckgivare Ekonomi SMP131-TSD-S

www.processcenter.se

### Technical specifications

#### Damping time

Total damping time constant: equal to the sum of damping time of amplifier and sensor capsule
Damping time of amplifier : 0-100S adjustable(with HART protocol)
Startup after power off :≤3S (HART output time: ≤ 6S)
Normal services after data recovery:≤4S (HART output time:≤31S)

#### Environment condition

Items	Operational condition
Working temperature	-40-85°C
Storage temperature	-40-100°C
Media temperature	-30-80°C
Working humidity	0-95%RH
Protection class	IP65
Dangerous condition	ExiaIICT4(GYB16.1964X)*
*Only for 4-20mA output	

### Technical Specifications

Signal output	4-20mA	4-20mA+HART*	0-5VDC	RS485
Power supply voltage	12-30VDC	10.5/16.5-55VDC	6-30VDC	5VDC/9-30VDC
Electric current	≤20.8mA		≤3.5mA	≤7mA
Load resistance(Ω)	<(U-12)/0.0208	<(U-10.5)/0.0208**	≥5k, recommend 100k	/
Transmission distance	<1000m		<5m	<1200m
Power consumption	≤500mW(20.8mA output@24VDC)		≤84mW(0-5VDC output, @24VDC)	≤168mW(RS485 output@24VDC)

\*For this output type, the load resistance value in communication is 250Ω

\*\*The load resistance value 0-2119Ω is in nominal working condition, 250-600Ω is HART communication

### EMC environment(not RS485 signal output)

NO.	Test items	Basic standards	Test conditions	Performance level
1	Radiated interference	GB/T 9254/CISPR22	30MHz-1000MHz	OK
2	Conducted interference (DC power port)	GB/T 9254/CISPR22	0.15MHz-30MHz	OK
3	Electrostatic discharge immunity test (ESD)	GB/T 17626.2/IEC61000-4-2	4kV(Contact), 8kV(Air)	B(Note2)
4	Immunity to radio frequency EM-fields	GB/T 17626.3/IEC61000-4-3	10V/m(80MHz-1GHz)	A(Note1)
5	Power frequency magnetic field immunity test	GB/T 17626.8/IEC61000-4-8	30A/m	A(Note1)
6	Electrical fast transient / Burst immunity test	GB/T 17626.4/IEC61000-4-4	2kV(5/50ns, 100kHz)	B(Note2)
7	Surge immunity requirements	GB/T 17626.5/IEC61000-4-5	1kV(Line to line) 2kV(Line to ground) (1.2us/50us)	B(Note2)
8	Immunity to conducted disturbances induced by radio frequency fields	GB/T 17626.6/IEC61000-4-6	3V(150kHz-80MHz)	A(Note1)

(Note 1)Performance level A: The performance within the limits of normal technical specifications.

(Note 2)Performance level B: Temporary reduction or loss of functionality or performance, it can restore itself. The actual operating conditions, storage and data will not be changed.

## Kompakt Tryckgivare Ekonomi SMP131-TSD-S

www.processcenter.se

### Product selection instruction

#### Sensor select instruction

Code	Nominal value	Description
S403G	40kPa	Range -40kPa-40kPa, smallest calibratable span 2kPa
S254G	250kPa	Range -100kPa-250kPa, smallest calibratable span 12.5kPa
S105G	1MPa	Range -100kPa-1MPa, smallest calibratable span 50kPa
S305G	3MPa	Range -100kPa-3MPa, smallest calibratable span 150kPa
S106G	10MPa	Range -100kPa-10MPa, smallest calibratable span 500kPa
S406G	40MPa	Range -100kPa-40MPa, smallest calibratable span 5MPa

Adjust requirements: lower range value (LRV) and upper range value (URV) can be adjusted within the scope of the upper and lower range limit, minimum measuring range  $\leq |URV - LRV| \leq$  maximum measuring range

Code	Item	Description
S	Isolated diaphragm material	SUS316L
H		Hastelloy C
S	Isolated filling fluid	Silicon oil filling, process temperature: -45-205°C
D		Fluorocarbon oil filling, process temperature: -45-160°C
F	Sensor seal	Stainless steel welding

#### Diaphragm (S/H)



#### Electrical connection select instruction

Code	Description
D1	DIN43650 Connector, IP65

#### DIN43650 ( D1 )



#### DIN43650(D 1)

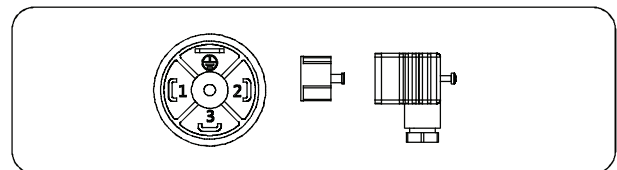

Label	Two wires	Three wires	Four wires	Modbus-RTU/RS485
1	Power+	Power+	Power+	Power+
2	Power-	Power-	Power-	Power-
3	Key-z	Signal+	Signal+	A+
⊕			Signal-	B-

Note: Key-z is modified zero pressure

## Kompakt Tryckgivare Ekonomi SMP131-TSD-S

www.processcenter.se

### Product selection instruction

#### Output signal select instruction

Code	Description
F	4-20mA two wire, power supply: 12-30VDC
H	4-20mA+ HART two wire, power supply: 16.5-55VDC
R	Modbus-RTU/RS485 5V/9-30VDC
1	1-5VDC three wire, power supply: 12-30VDC
2	0-5VDC three wire, power supply: 6-30VDC
5	0.5-4.5VDC three wire, power supply: 6-15VDC
A	4-20mA two wire, Intrinsic safety, power supply: 12-30VDC

#### Process connection select instruction

Code	Type	Description
6	Material	SUS316
M01	Specification	M20*1.5(M), $\Phi$ 3 pressure lead hole, GB/T193-2003, ISO261
G01		G1/2(M), $\Phi$ 3 pressure lead hole, EN837
G02		G1/4(M), $\Phi$ 3 pressure lead hole, EN837
G08		G1/4(M), $\Phi$ 3 pressure lead hole, GB/T7307, ISO228, DIN16288, BS2779, seal reference DIN3852-E ( back-end seal ) Max measuring range 60MPa
R01		1/2-14NPT(M), $\Phi$ 3 pressure lead hole, GB/T12716, ANSI/ASME B1.20.1
R02		1/4-18NPT(M), $\Phi$ 3 pressure lead hole, GB/T12716, ANSI/ASME B1.20.1
R03		1/2-14NPT(F), $\Phi$ 3 pressure lead hole, GB/T12716, ANSI/ASME B1.20.1
R04		1/4-18NPT(F), $\Phi$ 3 pressure lead hole GB/T12716, ANSI/ASME B1.20.1

## Kompakt Tryckgivare Ekonomi SMP131-TSD-S

www.processcenter.se

### Product drawing and dimension

Drawing and dimension of SMP131-TSD-S (unit: mm)

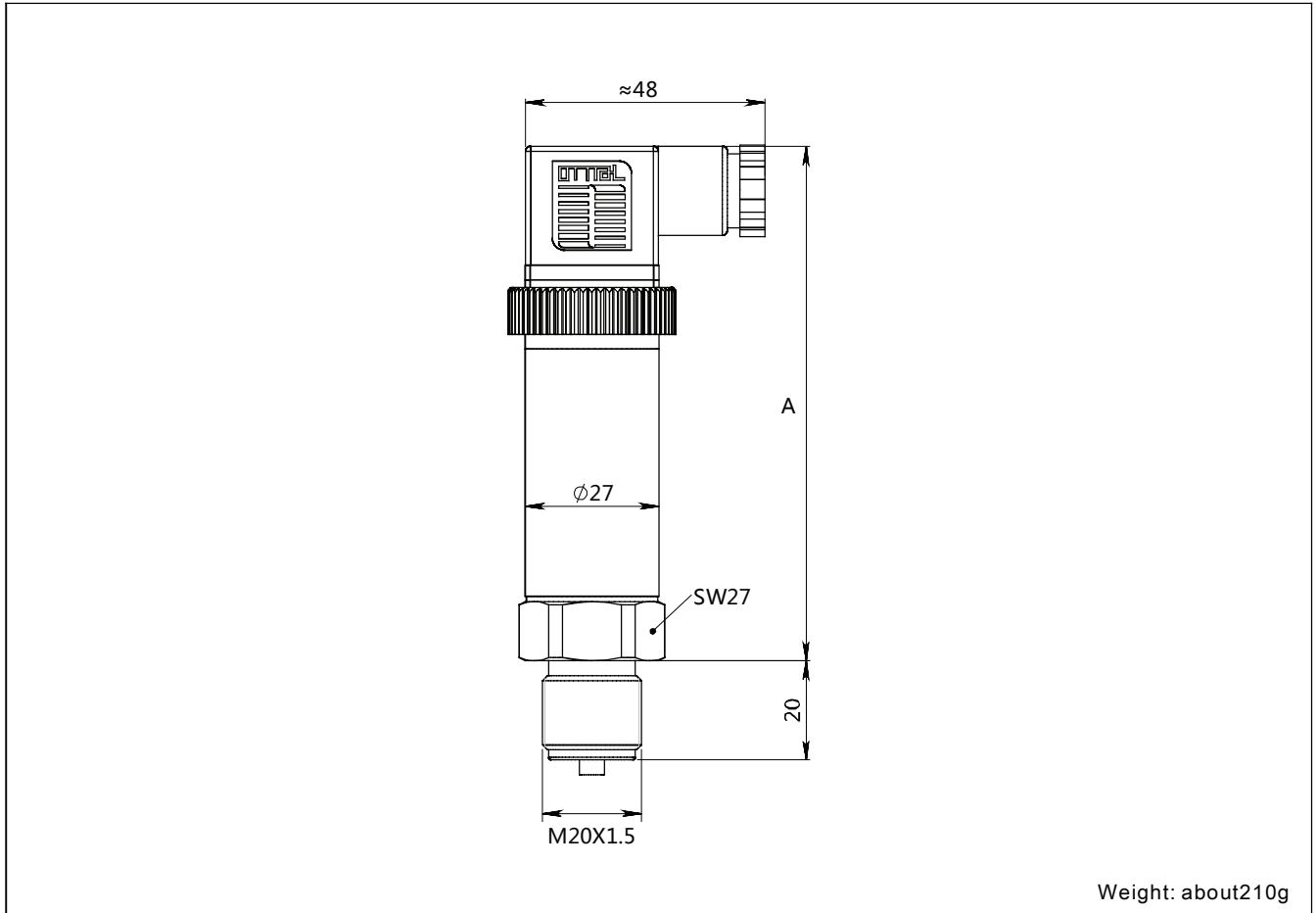

Process connection(M01) (unit: mm)

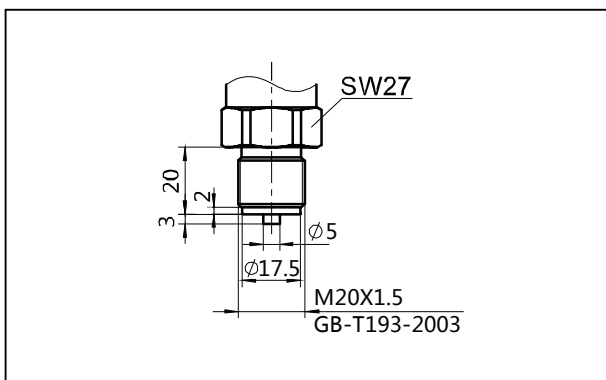

Process connection(G01) (unit: mm)

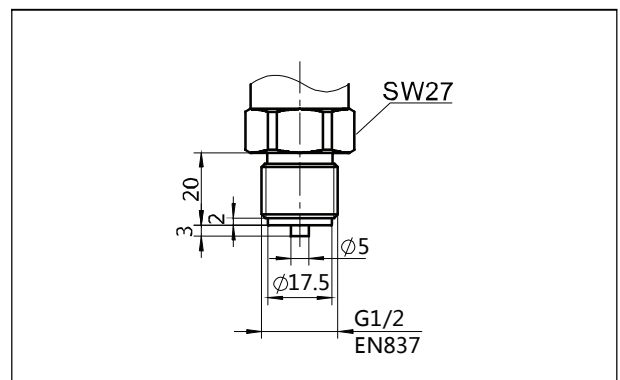

## Kompakt Tryckgivare Ekonomi SMP131-TSD-S

www.processcenter.se

### Product drawing and dimension

Process connection(G02) (unit: mm)

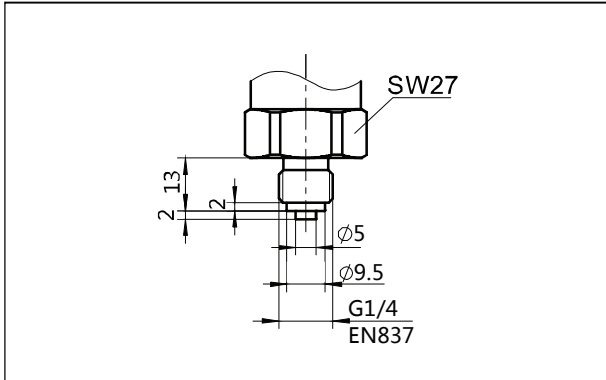

Process connection(G08) (unit: mm)

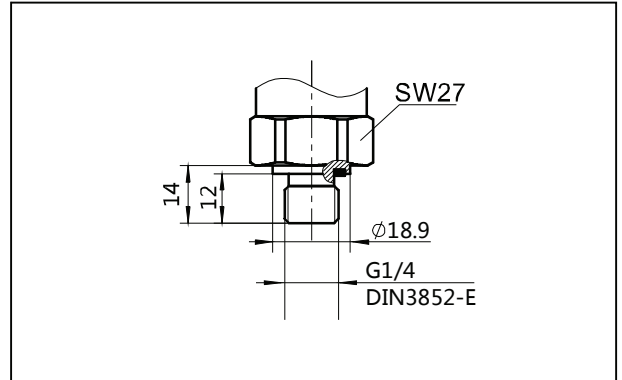

Process connection(R01) (unit: mm)

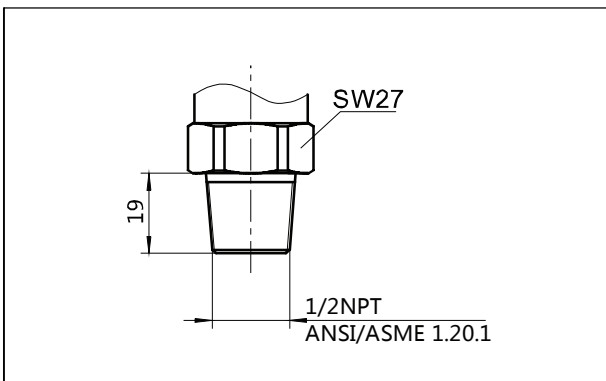

Process connection(R02) (unit: mm)

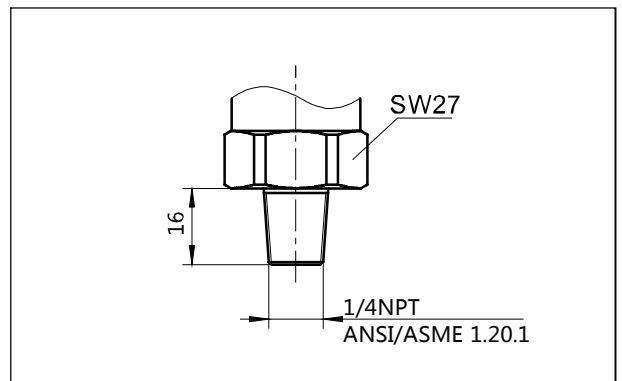

Process connection(R03) (unit: mm)

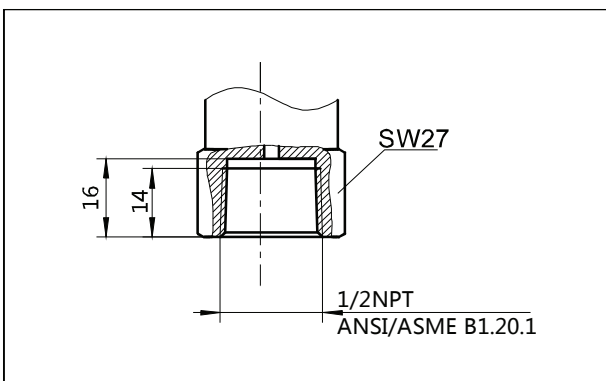

Process connection(R04) (unit: mm)

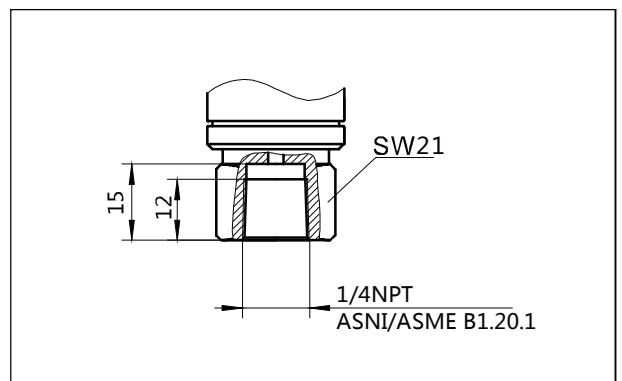



# Kompakt Tryckgivare Ekonomi SMP131-TSD-S

www.processcenter.se

## Product drawing and dimension

Heat exchange connector(N1) (unit: mm)

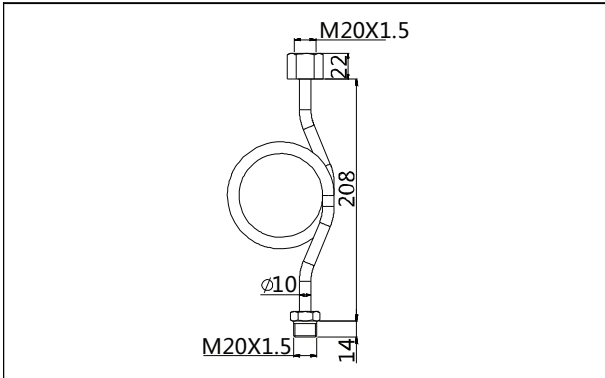

Heat exchange connector(N2)(unit: mm)

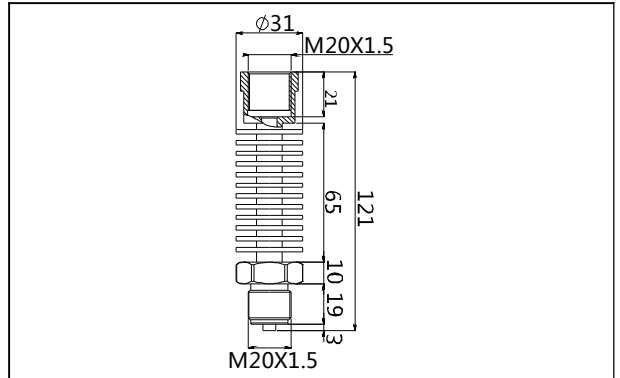

Welding adaptor(Z1) (unit: mm)

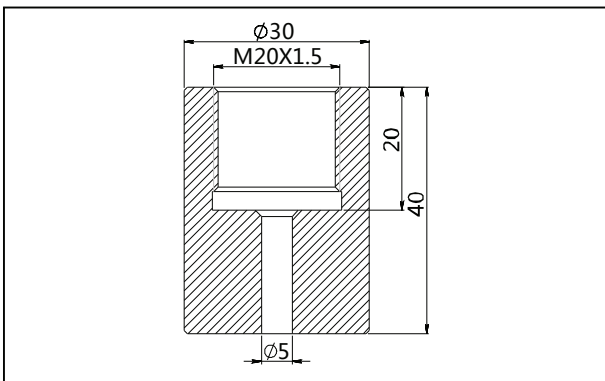

Welding adaptor(Z2) (unit: mm)

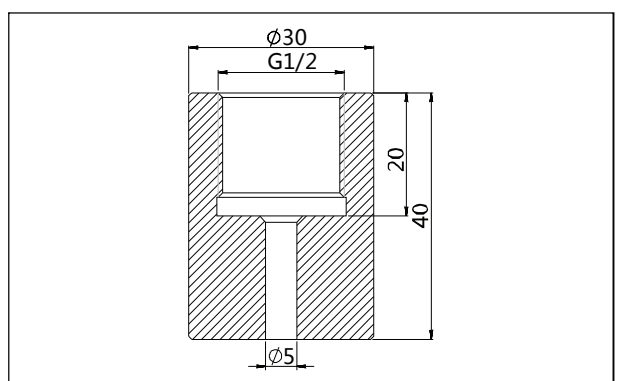



## Kompakt Tryckgivare Ekonomi SMP131-TSD-S

www.processcenter.se

### Ordering information chapter

Item	Parameters	Code	Instruction	(*) fast delivery available
	Model	SMP131-TSD	Monosilicon gauge pressure sensor	
Sensor	Separator	-	Detailed specifications as following	
	Pressure range code	S403G	Nominal value(URL): 40kPa	*
		S254G	Nominal value(URL): 250kPa	*
		S105G	Nominal value(URL): 1MPa	*
		S305G	Nominal value(URL): 3MPa	*
		S106G	Nominal value(URL): 10MPa	
		S406G	Nominal value(URL): 40MPa	
	Isolated diaphragm material	S	SUS316L	*
		H	Hastelloy C	
	Isolated filling fluid	S	Silicon oil filling, process temperature: -45-205°C	*
		D	Fluorocarbon oil filling, process temperature: -45-160°C	
	Sensor seal	F	Stainless steel welding	*
Electrical connection	Separator	-	Detailed specifications as following	
	Electrical connection	D1	DIN43650 connector, IP65	
	Cable entry protector	R0	None	
Output	Separator	-	Detailed specifications as following	
	Output signal	F	4-20mA two wire, power supply: 12~30VDC	*
		H	4-20mA+HART two wire, power supply: 16.5~55VDC	
		R	Modbus-RTU/RS485 four wire, power supply:5VDC/9-30VDC	
		1	1-5VDC three wire, power supply: 12-30VDC	
		2	0-5VDC three wire, power supply: 6-30VDC	
		5	0.5-4.5VDC three wire, power supply:6-15VDC	
		A	4-20mA two wire, intrinsic safety, power supply: 12-30VDC	
Tube type	Separator	-	Detailed specifications as following	
	Tube	53	Stainless steel tube length: 53mm (HART、Modbus-RTU/RS485 is not available)	*
		37	Stainless steel tube length: 37mm (HART、Modbus- RTU/RS485 is not available)	
		65	Stainless steel tube length: 65mm (with HART、Modbus- RTU/RS485, accuracy≤0.1%)	*
		85	Stainless steel tube length: 85mm (with HART、Modbus- RTU/RS485, accuracy≤0.1%)	
Process connection	Separator	-	Detailed specifications as following	
	Material	6	SUS316	*
	Specification	M01	M20*1.5 (M), Φ3 pressure lead hole, GB/T193-2003, ISO261	*
		G01	G1/2 (M), Φ3 pressure lead hole, EN837	*

## Kompakt Tryckgivare Ekonomi SMP131-TSD-S

www.processcenter.se

### Ordering information chapter

		G02	G1/4(M), $\Phi$ 3 pressure lead hole, EN837	
		G08	G1/4(M), $\Phi$ 3 pressure lead hole, GB/T7307, ISO228, DIN16288, BS2779, seal refers to DIN3852-E (back-end seal), maximum measuring range: 60 MPa	
		R01	1/2 -14NPT(M), $\Phi$ 3 pressure lead hole, GB/T12716, ANSI/ASME B1.20.1	
		R02	1/4 -18NPT(M), $\Phi$ 3 pressure lead hole, GB/T12716, ANSI/ASME B1.20.1	
		R03	1/2 -14NPT(F), $\Phi$ 3 pressure lead hole, GB/T12716, ANSI/ASME B1.20.1	
		R04	1/4 -18NPT(F), $\Phi$ 3 pressure lead hole, GB/T12716, ANSI/ASME B1.20.1	
Additional options	Separator	-	Detailed specifications as following	
	Process connection mounting accessory	/N1	Heat exchange connector, M20*1.5 (F) change to M20*1.5(M), SUS304 (Condenser pipe)	*
		/N2	Heat exchange connector, M20*1.5 (F) change to M20*1.5(M), SUS304 (Cooling fin)	
	Process connection accessory	/Z1	Welding adaptor, M20*1.5(F), SUS304	
		/Z2	Welding adaptor, G1/2(F), SUS304	
	Approvals (multiple)	/I1	Intrinsic safety certificate, ExialICT4, NEPSI (Please consult engineers for details)	
		/F3	CE certificate	
	Wetted parts treatment	/G1	Ungrease treatment	
		/G2	Electropolishing treatment	



## Kompakt Tryckgivare Ekonomi SMP131-TSD-S

www.processcenter.se

### Approvals

#### Factory certificate

Certification organization	Intertek
Quality management system	ISO9001-2008
Scope of certification	Design and production of pressure transmitter
Registration number	110804039

#### CE

Certificate organization	ISET
License scope	SMP131 series pressure transmitter
Mark	CE
EMC instruction	2014/30/EU
Standard	EN61326-1: 2013
Registration number	IT031353LG161207

#### Intrinsic safety certificate

Certification organization name	NEPSI
License scope	SMP131 series pressure transmitter
Explosion-proof mark	ExiaIICT4
Ambient temperature	-40-+60°C
Medium maximum temperature	+120°C
Registration number	GYB16.1964X
Intrinsically safe parameter description	Maximum input voltage: 28VDC
	Maximum input current: 100mA
	Maximum input power: 0.7w
	Maximum internal equivalent parametersCi(uF): 0
	Maximum internal equivalent parametersLi(mH): 0.01